

SECTION AT B-B

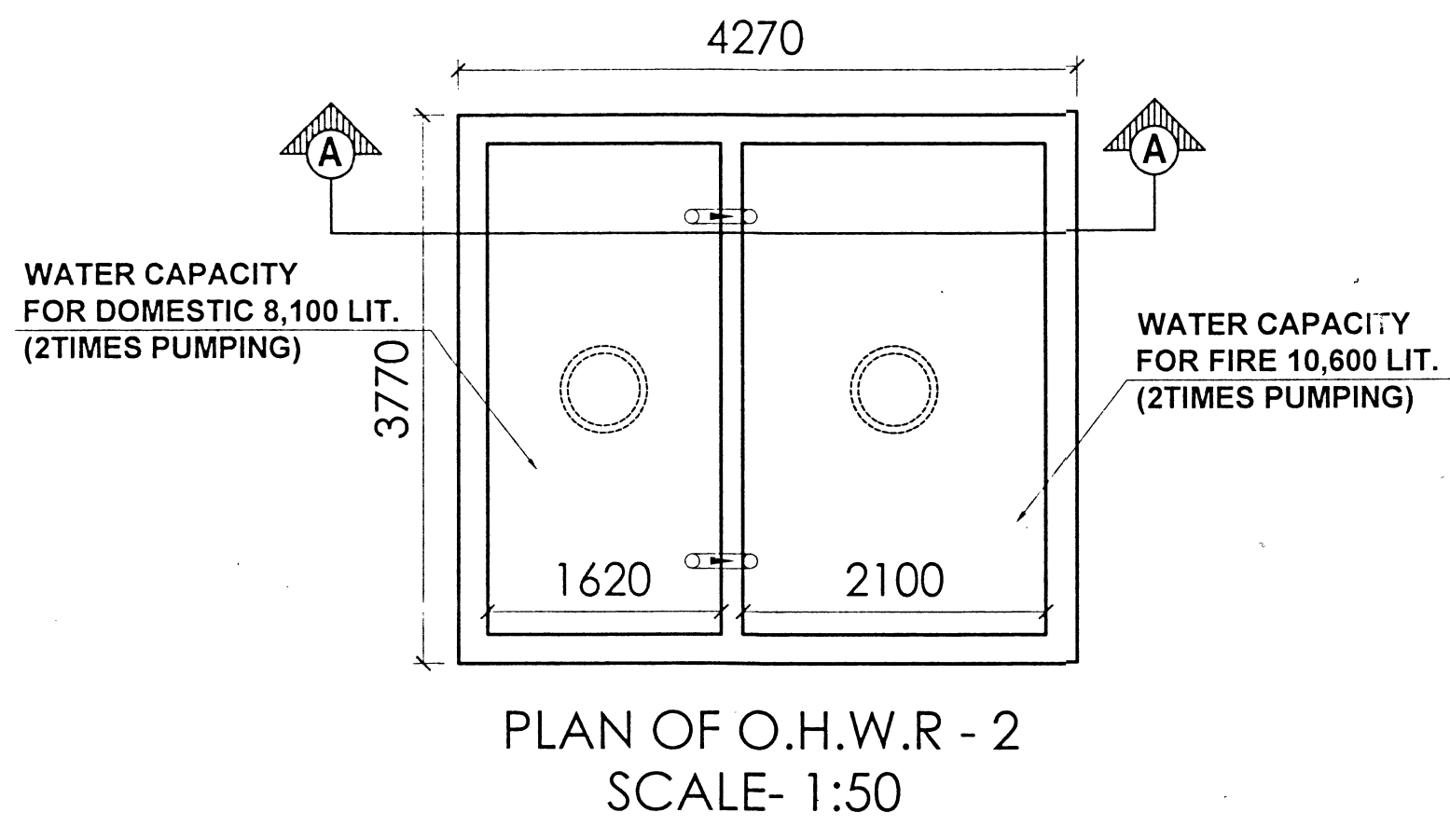

PLAN OF O.H.W.R - 2  
SCALE- 1:50

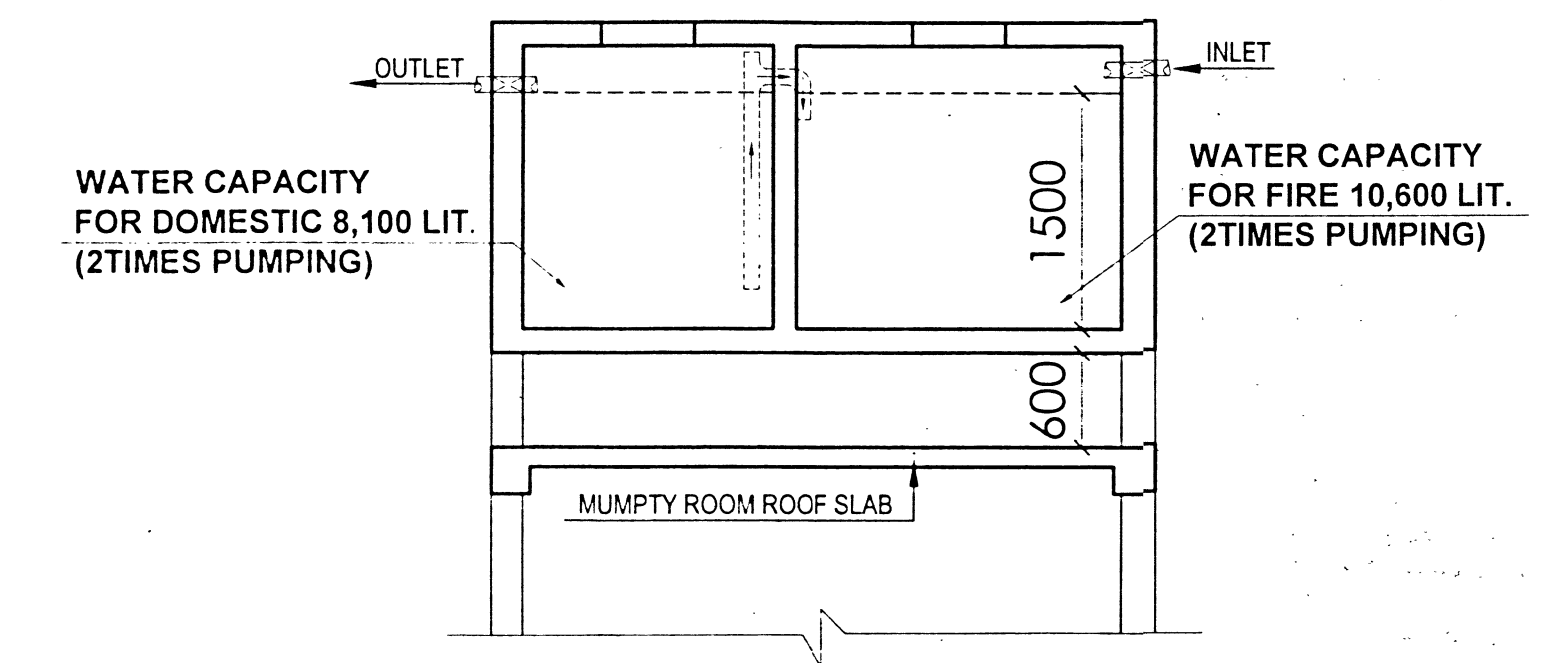

SECTION AT A-A  
SCALE- 1:50

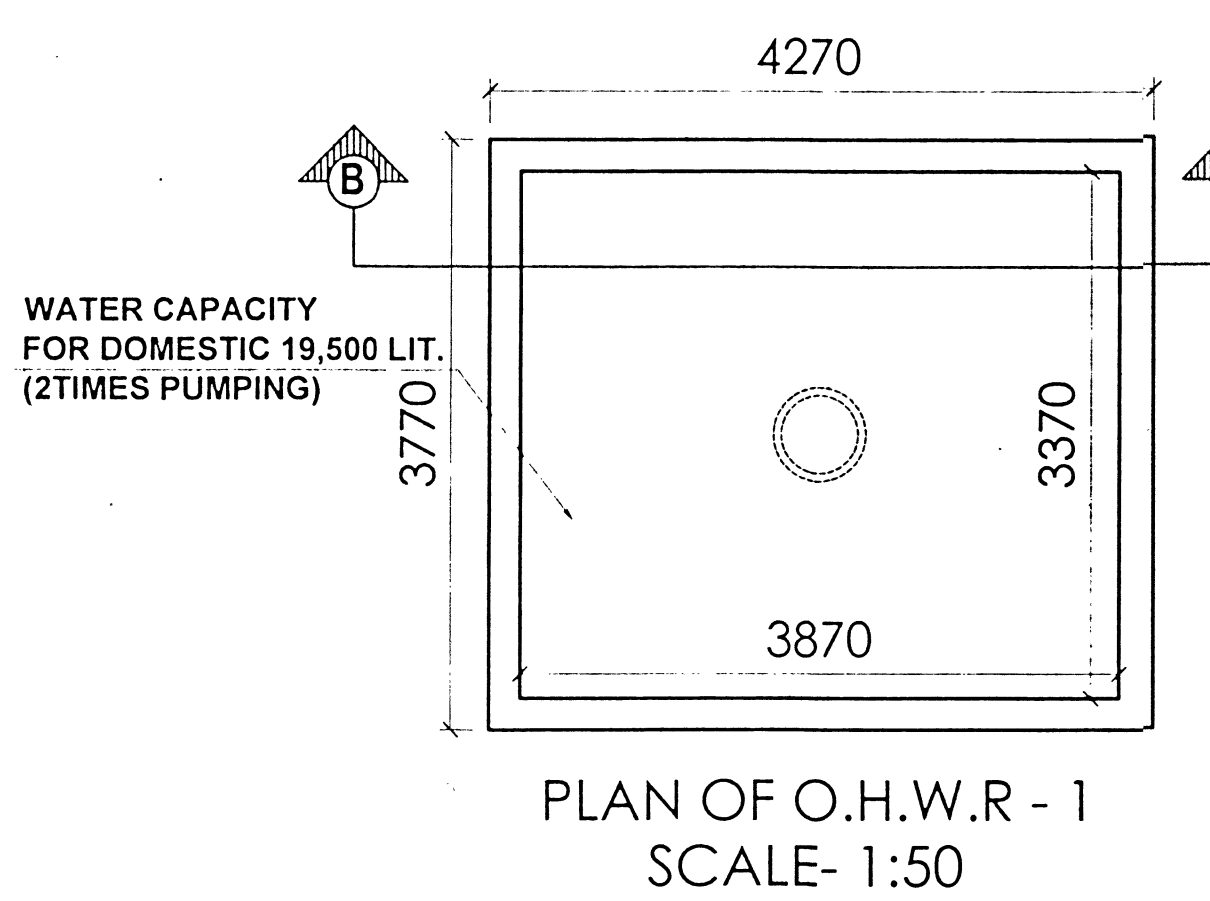

PLAN OF O.H.W.R - 1  
SCALE- 1:50

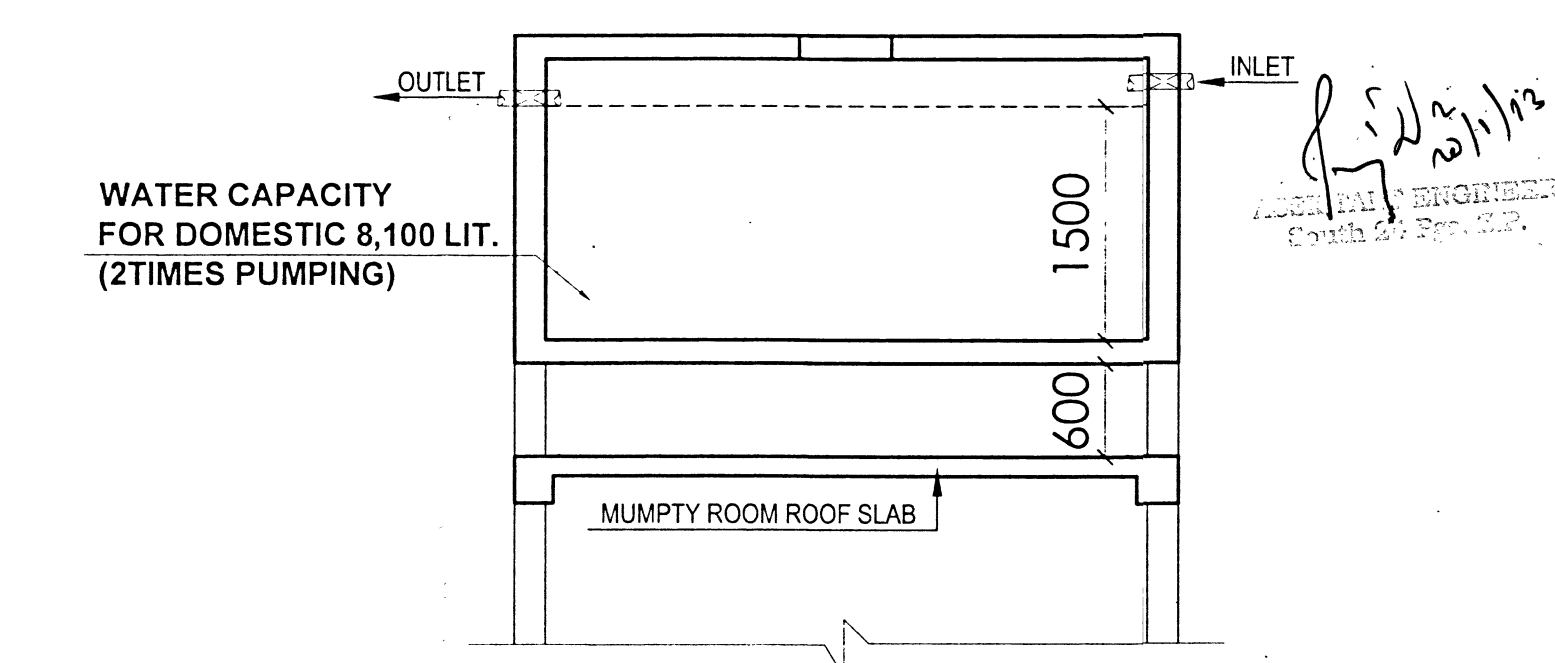

SECTION AT A-A  
SCALE- 1:50

- Vetted and recommended for sanction the building plan No. 714 344/E/E/K/M/2012, height 40.00m. Subject to the condition
- Before starting any construction, the site must conform with the plan sanctioned and all the condition as proposed in the plan should be fulfilled.
- All building materials necessary for construction should conform to standard specified in the I.S. Code of India.
- Necessary steps should be taken for safety of lives of the adjoining public and private property during construction.
- Construction site should be maintained to prevent mosquito breeding.
- Design of all Structural members including that of the foundation should conform to standard specified in the N.B.C. of India
- The sanction is valid for 3 years from date of sanctioning
- Information required by the applicant to this end are :-  
 - Commencement of work.  
 - Completion of structural work up to plinth.  
 - Completion of work.
- No rain water pipe should be fixed or discharged on Road or Footpath.
- The construction should be carried out as per specification of I.S. Code and sanctioned plan under the supervision of qualified empaneled engineers.
- Construction of garbage vat, sash pit & waste water should be done by the owners.
- Any deviation of the sanctioned plan shall mean demolition

1. There should not be any court case or any complains from any corner in respect of the said property as per plan.
2. "South 24 Parganas Zilla Parishad" will not be liable if any dispute arises at any time.

*[Signature]*  
District Engineer  
South 24 Pgs. Z.P.

FOR APPROVAL

**ADDITION OF EXTRA 8 NOS. FLOOR (i.e G+12) OVER EXISTING (G+4) STORIED RESIDENTIAL BUILDING AT MOUZA- UTTAR KAJIRAHAT ; J.L. 22, L.R. DAG NO-112(P),115(P),116(P),117(P) P.S.- BISHNUPUR, UNDER PASCHIM BISHNUPUR GRAM PANCHAYAT, DIST-SOUTH 24 PARGANAS, WEST BENGAL, PREVIOUSLY SANCTIONED (G+4) VIDE MEMO NO. 1292/4/ZP/Engg/JP/22 DATED 31.03.2022 FROM SOUTH 24 PARGANAS ZILLA PARISHAD**

I CERTIFY THAT ALL THE ARCHITECTURAL DRAWINGS OF THE PROJECT ADDITION OF EXTRA 8 NOS. FLOOR (i.e G+12) OVER EXISTING (G+4) STORIED RESIDENTIAL BUILDING AT MOUZA- UTTAR KAJIRAHAT ; J.L. 22, L.R. DAG NO-112(P), 115(P), 116(P), 117(P) P.S.- BISHNUPUR, UNDER PASCHIM BISHNUPUR GRAM PANCHAYAT, DIST- SOUTH 24 PARGANAS, WEST BENGAL HAVE BEEN PREPARED BY ME COMPLYING WITH THE PROVISIONS OF THE NATIONAL BUILDING AND THE WEST BENGAL MUNICIPAL BUILDING RULES. NO SUCH WRONG AND INCORRECT INFORMATION HAS BEEN FURNISHED BY ME INCLUDING AREA CALCULATION CHARTS IN THIS DRAWINGS AND NO VIOLATION OF THE PROVISIONS OF THESE RULES WILL BE FOUND IN ANY OF THE DRAWINGS AND DOCUMENTS, SUBMITTED TO THE SANCTIONING AUTHORITY FOR OBTAINING SANCTIONS.

*[Signature]*  
ATANU CHAKRABORTY  
Chartered Architect  
No. 24684

Signature of Architect  
**PRAKALPA**  
145, NANI GOPAL ROY CHOWDHURY AVENUE,  
Mezzanine & 2nd floor, KOLKATA - 700 014  
TEL: 033 64507757  
WEB SITE : www.prakalpa.in  
E-MAIL : prakalpa.arch@gmail.com

CERTIFY THAT THE STRUCTURAL DRAWING AND DESIGN OF BOTH THE FOUNDATION AND SUPERSTRUCTURE OF THE BUILDING/ BUILDINGS HAS BEEN MADE CONSIDERING THE SOIL TEST REPORT (AS PER THESE RULE AND REGULATIONS MADE UNDER THE ACT) AND ALSO CONSIDERING ALL POSSIBLE LOADS, SEISMIC LOAD AND THE MOMENTS GENERATED BY THE PROPOSED STRUCTURE AS PER CURRENT CODES. THE BUREAU OF INDIAN STANDARD AND NATIONAL BUILDING CODE OF INDIA AND CERTIFY THAT IT IS SAFE AND STABLE IN ALL RESPECT UP TO (G+XII) STORIES AND THESE PROVISIONS SHALL BE ADHERED TO DURING THE CONSTRUCTION.

*[Signature]*  
SANJIV J. PAREKH  
M.E. (STRUCT./M.F./CONST.ENG.),  
(CONSULTANT) CIVIL ENGINEER  
No. 40, B. S. ROAD, SOUTH 24 PGS. ZILLA PARISHAD

SIGNATURE OF THE STRUCTURAL ENGINEER

IT IS CERTIFIED THAT THE COMPREHENSIVE GEO-TECHNICAL REPORT ON SOIL INVESTIGATION HAS BEEN PREPARED BY ME FOR DESIGN AND CALCULATION OF THE FOUNDATION BY ANALYZING THE SOIL SAMPLES FOR ESTIMATING THE BEARING CAPACITY OF THE SOIL ON WHICH FOUNDATION OF THE STRUCTURE WILL BE CONSTRUCTED.

*[Signature]*  
RUPAK KUMAR BANERJEE  
B.C.E. M.E. M.I.S.  
M.I.E. CHARTERED ENGINEER (M.I.C.E.)  
ENLISTED GEO-TECHNICAL ENGINEER (M.I.G.E.)  
No. 14, 27/9, M-19387/15  
Signature of the Geo-Technical Engineer

*[Signature]*  
ANUSANDHAN COMMOTRADE PVT. LTD.  
Authorized Signatory

AUTHORIZED SIGNATORY

TITLE :  
SECTION AT B-B & DETAIL OF O.H.W.T

PROJECT ARCHITECT  
**PRAKALPA**

145, NANI GOPAL ROY CHOWDHURY AVENUE,  
Mezzanine & 2nd floor, KOLKATA - 700 014  
TEL: 033 64507757  
WEB SITE : www.prakalpa.in  
E-MAIL : prakalpa.arch@gmail.com

DRAWN BY :	TANIA
CHECKED BY :	ATANU C
APPROVED BY :	DATE : 14.09.22
SCALE :	1 : 100

SUBMISSION DRAWING	
DRAWING NO.	REVISION NO.
GEMS-SANC-AR -PR12-06	0