





Sl. NO. 8695  
VALUE 5000/-  
ISSUED TO Ruma Sivalayam (P) Ltd.  
ADDRESS: Bhy, Jal  
M

Swapan Kr. Goswami  
Stamp Vendor  
O.S.R. Office, Jalpaiguri  
License No. 1/2004/200  
Date

13.9.17



Tara  
Tara Agural  
@ Tara Deiklana



550  
Tara Agural  
@ Tara Deiklana

551  
Gobinda Ray

552  
Bibhu Ray

553  
Sankar Ray

554  
Sankar Ray

555  
Raj Kumar Ray

District Sub-Registrar  
Jalpaiguri

13 SEP 2017

Rajesh Prasad  
80 Shree Krishna Prasad

Tara Agarwal.  
@ Tara Ben'shan

Raj Kumar Agarwal  
Gobindu Roy

हिंदू कर्तव्य

हिंदू कर्तव्य

हिंदू कर्तव्य

हिंदू कर्तव्य

**BETWEEN**

KALPANA ROY SELF AND  
ON BEHALF OF NATURAL  
GUARDIAN OF MINOR SON  
JOHNNI ROY

RUMTEK DEVELOPERS PVT. LTD.

Sanjay Garg

DIRECTOR

1. **'RUMTEK DEVELOPERS PRIVATE LIMITED'** (PAN: AACR0011L), a private limited company incorporated under the provision of the Indian companies Act 1956, having its office at 'Sidhi Vinayak Enclave', Jyotinagar Road, Siliguri-734001, P.O. Sevoke Road, Siliguri, Dist-Jalpaiguri-- represented by one of its Directors, Sri Sanjay Kumar Garg, son of late, Khusi Ram Garg;
2. **'M/S TULSA ENTERPRISE'**, (PAN: AADFT1185G), a partnership Firm, having its office at 2<sup>nd</sup> Mile, Siliguri-734001, P.O. Sevoke Road, Siliguri, Dist.-: Jalpaiguri -- represented by its partners, namely Sri Suresh Kumar Agarwal and Sri Sanjay Garg, both sons of Late Amilal Agarwal and
3. **SRI PRADIP AGARWAL**, (PAN: ACRPA2125P) Son of late Ram Chandra Agarwal, resident of Church Road, Siliguri, Dist-Darjeeling.

-- hereinafter collectively called the **'PURCHASERS'** (Which expression shall mean and include unless excluded by or repugnant to the context their heirs, executors, successors -in-office, representatives, administrators and assigns) of the **'FIRST PART'**

Raj Kumar



558

RUMTEK DEVELOPERS PVT. LTD.

Sanyu Gu

DIRECTOR



  
District Sub-Registrar  
Jalpaiguri

13 SEP 2017



Tara Agarwal  
@ Tara Devi Sharma

Raj Kumar Agarwal

Gobindu Roy

Sri Sanjay

**AND**

Sri Hiram

Sri Hiram

Sri Hiram

KALPANA ROY SELF AND

ON BEHALF OF NATURAL

GUARDIAN OF MINOR

SON JOHNNI ROY

RUMTEK DEVELOPERS PVT. LTD.

Saji Roy

DIRECTOR

1. **SMT. TARA AGARWAL @ TARA DEVI SHARMA**, (PAN: DTTPS4030R),

Wife of Sri Sanjay Agarwal, Hindu by faith, Indian by Nationality, Business by occupation, resident of 2<sup>1/2</sup> Miles, P.O. Sevoke Road, Siliguri, & P.S. Bhaktinagar, Dist-Jalpaiguri and also of 6<sup>th</sup> Mile, Tadong, Gangtok, 737102, East Sikkim and;

2. **SRI RAI KUMAR AGARWAL**, (PAN: AFXPA2950B),

Son of Late Parshuram Agarwal, Hindu by faith, Indian by Nationality, Business by occupation, resident of 2<sup>1/2</sup> Miles, P.O. Sevoke Road, Siliguri, & P.S. Bhaktinagar, Dist-Jalpaiguri and also of R.C. Mintri Road, P.O. & P.S. Kalimpong, Dist-Darjeeling

-- hereinafter collectively called the '**VENDORS**' (Which expression shall mean and include unless excluded by or repugnant to the context their heirs, executors, successors,, representatives, administrators and assigns) of the

**'SECOND PART'**

**AND**

1. **SRI GOBINDA ROY**, (PAN: AYHPR5886Q),

2. **SRI HIRAMBHA RAY**, (PAN: AYHPR5946D),

3. **SMT. JAMINI ROY** (PAN: BDAPR2158A),

--No. 1 and 2 are sons and No. 3 is the Wife of Late Dharendra Nath Roy,

*Agarwal*



  
District Sub-Registrar  
Jalpaiguri

13 SEP 2017

Tara Agrawal  
@ Tara Devi Singh

Raj Kumar Ayya  
Gopinath Roy  
Sri Johnni Roy

21st April 2017  
21st April 2017  
21st April 2017

KALPANA ROY SELF AND  
ON BEHALF OF NATURAL  
GUARDIAN OF MINOR  
SON JOHNNI ROY

Signature  
S. J. Roy  
DIRECTOR

4. (a) SMT. KALPANA ROY (PAN: AYIPR6379M)

(b) SRI JOHNNI ROY

--No. 4 (a) is the widow and no. 4(b) is minor son of Late Chaitnya Roy & all Hindu by faith, Indian by Nationality, residents of Prakash Nagar, (Ram Chandra Nagar), near Chittrakut Ashram, 2<sup>1</sup>/<sub>2</sub> Miles Check Post, P.O. Salugara, Ward No. 42 of the Siliguri Municipal Corporation, P.S. Bhaktinagar, Dist- Jalpaiguri;

--No. 4(b) being minor, as such represented by her mother/next friend, Smt. Kalpana Roy, 4 (a).

---- hereinafter collectively called the **'THE CONFIRMING PARTY'** (Which expression shall mean and include unless excluded by or repugnant to the context their heirs, executors, successors,, representatives, administrators and assigns) of the **'THIRD PART'**

**WHEREAS** certain Dharendra Nath Roy alias Dharendra Roy, son of late Bishoy Singh Roy of Dabgram area became the owner and 'raiya' of considerable landed property, including ALL THAT a piece of land, admeasuring 4.52 acres and during settlement survey operation under the provisions of W.B. Estate Acquisition Act 1953 his name got recorded in the record, maintained by the concerned Land or Land Reform office and ultimately a finally published record-of-right was opened in

Registered



  
District Sub-Registrar  
Jalpaiguri

13 SEP 2017



Tare Agnani  
@Tan Devishan

Rajkumar Roy

Gadinda Roy

Neel Rishi

512 LG 12/10/12

five months

five months

KALPANA ROY SELF

AND ON BEHALF OF

NATURAL GUARDIAN

OF MINOR SON

JOHNNI ROY

RUMTEK DEVELOPERS PVT. LTD.

5073 607

DIRECTOR

the name of said Dharendra Nath Roy alias Dharendra Roy and the same was latter modified and reexamined under Sec. 44 (2a) of the same Act and finally for all reasonable and practical purposes said Dharendra Nath Roy was entitled to have owned, enjoyed and possessed said land, admeasuring 4.52 acre appertaining to and comprised within part of R.S. Plot No. 133, covered and recorded by Khatian No. 83/1 (R.S.) of Sheet No. 5 (R.S.) & 4 (L.R.), Mouza- Dabgram, J.L. No. 2, P.S. Bhaktinagar, Dist-Jalpaiguri and by lapse of time the right, title and interest, as well as ownership in respect of said land of Dharendra Nath Roy became beyond any doubt whatsoever. During lifetime of said Dharendra Nath Roy, he had been holding, enjoying and occupying the entire recorded land, i.e. 4.52 acres continuously, uninterruptedly and without any sorts of outward influence or hindrance whatsoever..

**AND WHEREAS** during lifetime, said Dharendra Nath Roy did dispose of and transfer part of his recorded land measuring 1.50 acres for valuable consideration in favour of Smt. Kamala Devi Kajaria, wife of Sri Ram Niranjana Kajaria of Siliguri Town on 4<sup>th</sup> October 1963 by dint of a registered deed of sale, bearing NO. I-5728 for the 1963 of the office of Dist. Sub- Registrar, Jalpaiguri and accordingly said Smt. Kamala Devi Kajaria started holding, enjoying and possessing her acquired/purchased land, admeasuring 1.50 acres being the absolute owner thereof.

Rajkumar



  
District Sub-Registrar  
Jalpaiguri

13 SEP 2017

Tara Agarwal.  
@ Tara Devi Sharma

Raj Kumar Agarwal  
Gopinath Roy  
Kishor Kumar  
Sudip Kumar  
Raj Kumar  
KALPANA ROY SELF  
AND ON BEHALF OF  
NATURAL GUARDIAN  
OF MINOR SON  
JOHNNI ROY

1. Smt. Kamala Devi Kajaria including the above land, measuring 1.50 acres became the owner-in-possession of altogether 3.74 acres of land, appertaining to Plot No. 133, 133/370, covered by R.S. Khatian No. 83/1 after several purchase i.e. by dint of registered deeds of conveyance, bearing no. I- -20, dtd. 04.01.1960, I-4265, dtd. 20.05.1963, I-5728, dtd. 13.10.1963, all registered at the office of Dist. Sub-Registrar, Jalpaiguri.
2. However, out of the aforesaid purchase, said Smt. Kamala Devi Kajaria had been delivered the actual and physical possession of land measuring 1.50 acres in plot no. 133 and land measuring 2.24 acres in plot no. 133/370.
3. While enjoying the above land, said Smt. Kamala Devi Kajaria did also sell and transfer land measuring altogether 60 Cottah 6 Chhatak, in R.S. Plot no. 133 out of her purchased/ acquired 3.74 acres of land for valuable consideration in execution of two registered deeds of conveyance, bearing no. I-4667 and no. I-3894, both for the year 2003, which were registered at the office of the Dist. Sub-Register, Jalpaiguri unto the favour of Smt. Tara Agarwal (i.e. the vendors no.1 herein).
4. Smt. Tara Agarwal also became the owner of 14 Cottah 8 Chhatak of land by purchasing the same for valuable consideration from certain 'Pass Builders Pvt. Ltd.', in execution of another registered deed of conveyance, bearing no. I-

Agarwal





  
District Sub-Registrar  
Jalpaiguri

13 SEP 2017

Tara Agarwal  
@ Tara Developers

Rajkumar Agarwal  
Gopintha Roy  
Rishi K S & Co

Rishi K S & Co  
Rishi Mohan  
Rishi Mohan

KALPANA ROY SELF  
AND ON BEHALF OF  
NATURAL GUARDIAN OF  
MINOR SON

JOHNNI ROY

RUMTEK DEVELOPERS PVT. LTD.

S. S. S. S.

DIRECTOR

4656 for the year 2003 and another piece of land measuring 1 Cottah 8 Chhatak from certain 'Happy Homes and Resort Pvt. Limited' by dint of a registered deed of conveyance, bearing no. I-2626 for the year 2005 and thus Smt. Tara Agarwal became the owner and otherwise entitled to own, hold and enjoy altogether 76 Cottah 6 Chhatak (60 Cottah 6 Chhatak + 14 Cottah 8 Chhatak + 1 Cottah 8 Chhatak) of land in Plot No. 133 and thus said Smt. Tara Agarwal started holding, enjoying and possessing the above figured land continuously, freely and quietly having all sorts of right, title and interest, which is permanent, heritable and transferable one without any one's interruption whatsoever.

5. It is noted here that the vendors of Smt. Tara Agarwal, so far her purchased 14 Cottah 8 Chhatak of land is concerned, namely 'Happy Homes and Resort Pvt. Limited' actually it had got altogether 1.05 acres of land after purchasing the same from said Smt. Kamala Devi Kajaria for valuable consideration in execution of a registered deed of conveyance, being no. I-1130 for the year 2000 followed by a deed of rectification, being no. 129 for the year 2003. Out of said 1.05 acre or say 63 Cottah, a piece of land measuring 16 Cottah is in R.S. Plot no. 133 and remaining 47 Cottah land is in R.S. Plot No. 133/370 and in turn said 'Happy Homes and Resort Pvt. Limited' sold 14 Cottah 8 Chhatak

Agarwal



  
District Sub-Registrar  
Jalpaiguri

13 SEP 2017



Tara Agarwal  
Tara Agarwal

Raj Kumar Agarwal

Gopinanda Roy

Rajendra Singh

2nd floor

1st floor

2nd floor

KALPANA ROY SELF

AND ON BEHALF OF

NATURAL GUARDIAN

OF MINOR SON

JOHNNI ROY  
KUMAR BUILDERS PVT. LTD.  
Sriji Roy  
DIRECTOR

in favour of 'Pass Builders Pvt. Ltd.', by a registered deed of sale, bearing no. I-2188 for the year 2003 of the office of the D.S.R, Jalpaiguri.

6. it is also claimed that Smt. Tara Agarwal being the owner of altogether 76 Cottah 6 Chhatak of land did transfer a piece of land measuring 30 Cottah unto the favour of her husband, Sri Sanjoy Agarwal by making an absolute gift, which was registered at the office of the District Sub- Registrar, Jalpaiguri by the Deed of Gift, being no. I-350 for the year 2008 and in turn said Sri Sanjoy Agarwal made another absolute gift in respect of his entire acquired 30 Cottah of land in favour of his brother, namely Sri Raj Kumar Agarwal (i.e. the vendors no. 2 herein), which is also registered at the office of the District Sub-Registrar, Jalpaiguri in execution of a Deed of Gift, being no. I-482 for the year 2008 and soon with the registration of the said deed of gift, the Donee thereof, namely Sri Raj Kumar Agarwal started enjoying and possessing the above figured land continuously, freely and quietly having all sorts of right, title and interest, which is permanent, heritable and transferable one without any one's interruption whatsoever..

Tara Agarwal

7. And thus Smt. Tara Agarwal, being the owner of her purchased land measuring 46 Cottah 6 Chhatak and Sri Raj Kumar Agarwal, being the owner of his acquired land measuring 30 Cottah (hereinafter referred to as the VENDORS HEREOF)



  
District Sub-Registrar  
Jalpaiguri

13 SEP 2017

Tara Agnwal  
@ Tara Devi Sharma

Rajkumar Agnwal  
Gobind Roy

Five Nos. Khasra  
in the village  
of KALPANA RUI SELF  
AND ON BEHALF OF  
NATURAL GUARDIAN  
OF MINOR SON

KALPANA RUI SELF  
AND ON BEHALF OF  
NATURAL GUARDIAN  
OF MINOR SON

OF MINOR SON

RUMTEK DEVELOPERS PVT. LTD. T. CHANNI ROY

Soni G. J.

DIRECTOR

have been continuously occupying and possessing the land altogether measuring 3 bigha 16 cottah 6 chhatak, as aforesaid.

**AND WHEREAS** subsequently, disputes as to right, title and interest over the acquired land of the vendors grew up against the legal heirs of Late Dharendra Nath Roy and finding no other alternative the Vendors hereof, being the plaintiffs initiated a civil suit, numbering Title Suit No.. 151 of the 2010 before the Court of the Ld. Civil Judge, Senior Division at Jalpaiguri against the said legal heirs i.e. the confirming party herein.

The Confirming Party hereof i.e. legal heirs of Late Dharendra Nath Roy also filed another civil suit, numbering Title Suit No. 160 of the 2010 before the Court of the Ld. Civil Judge, Junior Division at Jalpaiguri against the vendors and ultimately in the said suit, at the intervention of some common friends of the rivalries, a compromise decree according to terms of *Solenama* was passed on <sup>13.09.17</sup> and thereby the right, title and interest of the vendors was confirmed from the date of purchase/acquire of their land, including that of their predecessors-in-interest, namely Smt. Kamala Devi Kajaria.

Tara Agnwal  
@ Tara Devi Sharma

Agarwal

AND WHEREAS now the Vendors being need of money and have decided to sell the below schedule land measuring 76 Cottah 6 Chhatk and ~~20 sq.ft.~~ <sup>20</sup> to the

pg. 9

Tara Agnwal  
@ Tara Devi Sharma





District Sub-Registrar  
Jalpaiguri

13 SEP 2017



District Sub-Registrar  
Jalpaiguri

13 SEP 2017

Tara Aggarwal  
@TaraDevish

Raj Kumar Agarwal  
Gobinda Roy

Neel Kishore

212 LG 13/14

212 LG 13/14

212 LG 13/14

KALPANA ROY SELF  
AND ON BEHALF OF

NATURAL GUARDIAN  
OF MINOR SON

JOHANNI ROY

RUMTEK DEVELOPERS PVT. LTD.

S. J. S.

DIRECTOR

interested buyer and after knowing the said decisions of the vendors, the Purchasers hereof became interested to purchase the land with a valuable consideration of Rs. 7,50,00,000.00 (Rupees Seven Crore Fifty Lacs) free from all encumbrances, charges and whatsoever.

AND WHEREAS the vendors have accepted the said offer and jointly and severally agreed to sell the said piece and parcel of the aforesaid land measuring 76 Cottah 6 Chhatk , as described in the schedule below by paying the said consideration to the Vendors.

AND WHEREAS the Vendors have agreed to sell the piece of land measuring 76 Cottah 6 Chhatk , as described in the Schedule below of these presents together with full right, title and interest which is free from all encumbrances against the said price of Rs. 7,50,00,000.00 (Rupees Seven Crore Fifty Lacs) only to the purchaser and the aforesaid piece of landed property is transferred hereby in the manner hereinafter appearing.

NOW THIS INDENTURE WITNESSETH that in pursuance of the aforesaid offer, acceptance and in consideration of Rs. 7,50,00,000.00 (Rupees Seven Crore Fifty Lacs) only paid by the purchaser this day to the Vendors, ( the receipt whereof

*M. J. S.*



Tara Agnyal  
@ Tara Distrikt

Raj Kumar Agnyal  
Gobinda Roy

Rishi Kishore

Rishi Kishore

Rishi Kishore

Rishi Kishore

KALPANA ROY SELF  
AND ON BEHALF OF  
NATURAL GUARDIAN  
OF MINOR SON  
JOHNNI ROY

the vendors also do hereof acknowledge as having as having received the same and vendors also do grant full discharge to the purchaser from the payment thereof) vendors do hereby convey, assign, sell and transfer absolutely and whatever the below scheduled land to gether with all rights, title and interest, hereditaments, liberties, easements etc, whatsoever in anyway belonging to reputed to belong therewith and make over the possession thereof unto and in favour of the Purchaser TO HAVE AND TO HOLD the same by the purchaser as absolutely owner thereof, peaceful and quietly with permanent heritable transferable a marketable right and without claim objection, interference or interruption from the Vendors or any person claiming therein subject to the payment of land payment to the superior Landlord, Govt. of W.B.

That after the transfer of the land, the purchaser shall enjoy and possess the same as per their sweet choice and will and at this the vendors or any person under them shall have no objection at all material times;

That the vendors doth hereby covenant that the vendors and/or all persons claiming any interest under them shall from time to time and at all times hereafter at the request and cost of the purchaser shall execute all such acts, deeds and things whatsoever for further and more effectively/ effectually assuring the enjoyment and possession of the purchaser thereof as may be required.

*Signature*

RUMTEK DEVELOPERS PVT. LTD.

*Signature*

DIRECTOR



  
District Sub-Registrar  
Jalpaiguri

13 SEP 2017

Taru Agard  
@Taru Dev'shina

Raj Kumar Agard  
Gobinda Roy

Ujjit Bisoi

Ziz Goswami

Rite Mo Foud

Rite Mo Foud

KALPANA RUY SELF AND  
ON BEHALF OF NATURAL

GUARDIAN OF MINOR SON

JOHANI ROY

RUMTEK DEVELOPERS PVT. LTD.

Srijit Sanyal

DIRECTOR

AND further that notwithstanding any act, deed, matters and things whatsoever by the vendors or any of their predecessors-in-title/interest done, committed or knowing suffered to the contrary the vendors have good right, full power and absolute authority to sell, grant, convey, transfer, assign and assure the said below schedule property unto and infavour of the purchaser in the manner as aforesaid;;

AND further the confirming party hereof for relinquishing their every right unto the favour of the vendors herein as per the *Solenama*, submitted in Title Suit No. 160 of 2010 will get a sum of Rs. 60,000,00.00 (Rupees Sixty Lacs) as compensation.

### SCHEDULE OF THE LAND

[HEREBY TRANSFERRED]

ALL THAT a piece or parcel of land, ad measuring 76 Cottah 6 Chhatak, comprised in R.S. Khatian No. 83/1, appertaining to R.S. Plot No. 133 of Sheet No. 5 (R.S.) & 4 (L.R.), Mouza- Dabgram, J.L. No. 2, P.S. Bhaktinagar, Dist-Jalpaiguri and located within the Ward No. 42 of the Siliguri Municipal Corporation.

(The above land is more particularly delineated in a sketch map, annexed with this indenture, being a part thereof)

Rajiv





  
District Sub-Registrar  
Jalpaiguri

13 SEP 2017

The said land is bounded as FOLLOWS:

By the North: 20 ft wide Road;

By the South: land of Bhawarlal Jain and Plot No. 133 (p);

By the East: Eastern Bypass;

By the West: Sevoke Road.

IN WITNESS WHEREOF THE VENDORS OF THESE PRESENTS have set and subscribed their hands on sound mind and health and after appreciating the contents of the documents on the date, month & year as first mentioned.

Witnesses:

Deep Basad  
S/o Shree Krishna Basad  
Gurunank Sabam,  
Punjabipara,  
Siliguri-734001.

Tara Agural  
@ Tara Devi Sharma  
Raj Kumar Agural  
Signature of the vendors

② Rodhy Shyam Sharma  
S/o Late B.D. Sharma  
25/20 Nalin Ser Road  
Siliguri-734001

Rajeev



  
District Sub-Registrar  
Jalpaiguri

13 SEP 2017



Tara Aggarwal  
@ Tara Deviskumar

Raj Kumar Aggarwal

Gobinda Roy

কল্যাণ রায়

স্বাক্ষরিত

কল্যাণ রায়

কল্যাণ রায়

KALPANA ROY SELF AND ON  
BEHALF OF NATURAL GUARDIAN  
OF MINOR SON JOHNNI ROY

RUMTEK DEVELOPERS PVT. LTD.

স্বাক্ষরিত

DIRECTOR

Signature of the Confirming Parties

DRAFTED BY ME &

PREPARED AT MY OFFICE



RAJAT DAS, Advocate

Siliguri  
Enrol.No. WB/ 38/1997



District Sub-Registrar  
Jalpaiguri

13 SEP 2017

# MEMO OF CONSIDERATION

The sale consideration price of Rs. 7,50,00,000.00 (Seven Crores & Fifty Lakhs Only) shall be paid in the following manner:

Vendors:

1. Smt Tara Agarwal alias Smt Tara Devi Sharma, will get a sum of Rs. 4,55,00,000.00 (Rupees Four Crores Fifty-Five Lakhs Only) vide a cheque being no 679805, dated 13/09/2017 amounting to Rs. 3,45,00,000.00 drawn on IDBI Bank, Siliguri, and another sum of Rs. 1,10,00,000.00 (Rupees One Crore Ten Lakhs Only) by a demand draft, being no. 657092 of SBI, SME Branch, Siliguri.
2. Sri Raj Kumar Agarwal will get a sum of Rs. 2,95,00,000.00 (Rupees Two Crores Ninety-Five Lakhs Only) vide a cheque being no 874589, dated 13/09/2017 amounting to Rs. 1,00,00,000.00 drawn on SBI Bank, Sevoke Road, Siliguri, and another sum of Rs. 42,05,000.00 (Rupees Forty-Two Lakhs and Five Thousand Only) vide cheque, being no. 000765 of HDFC Bank, Panitanki More, Siliguri, and another sum of Rs. 1,50,00,000.00 (Rupees One Crore and Fifty Lakhs Only) vide cheque no. 000766, drawn at HDFC Bank, Panitanki More, Siliguri.

Apart from the sale consideration, the confirming party will get a sum of Rs. 60,00,000.00 (Rupees Sixty Lakhs Only), as compensation in the following mode:

Name	Amount	Cheque
1. Shri Gibinda Roy	Rs. 15,00,000.00	043509, SBI, SME Branch, Siliguri
2. Shri Hiramba Ray	Rs. 15,00,000.00	043510, SBI, SME Branch, Siliguri
3. Smt Jamini Roy	Rs. 15,00,000.00	043508, SBI, SME Branch, Siliguri
4. Smt Kalpana Roy	Rs. 10,00,000.00	043511, SBI, SME Branch, Siliguri
5. Shri Johnni Roy	Rs. 5,00,000.00	043512, SBI, SME Branch, Siliguri

Signature:

*Lajesh Basak*  
 s/o Shree Kirehna Basak  
 Gurunankh Sasan, Puyabipasa  
 P.O - SILIGURI - 734001.

*Radhya Shyam Chow*  
 s/o Late B. D. Shome  
 25/20 nalan su road

*Siliguri - 734001*  
 (WITNESS)

*Tara Agarwal @ Tara Devi Sharma*  
*Raj Kumar Agarwal*  
 KALPANA ROY  
 SELF AND ON  
 BEHALF OF  
 NATURAL GUARDIAN  
 OF MINOR SON  
 JOHNNI ROY







District Sub-Registrar  
Jalpaiguri

13 SEP 2017

**CONFIRMING PARTY**

1. SRI. GOBINDA ROY
2. SRI. HIRAMBHA ROY
3. SMT. JAMINI ROY

NO. 1 & 2 ARE SONS & NO. 3 IS THE WIFE OF LATE DHIRENDRA NATH ROY

4. (a) SMT. KALPANA ROY
- 4.(b) SRI. JOHNNI ROY

NO. 4 (a) IS THE WIDOW & NO. 4(b) IS THE SON OF LATE CHAITANYA ROY

**VENDORS**

1. SMT. TARA AGARWAL  
W/O SRI. SANJAY AGARWAL
2. SRI. RAJ KUMAR AGARWAL  
S/O LATE PARSHURAM AGARWAL

*Tara Agarwal  
@ Tara Devi Sharma*

*Raj Kumar Agarwal*

SIGN OF VENDORS

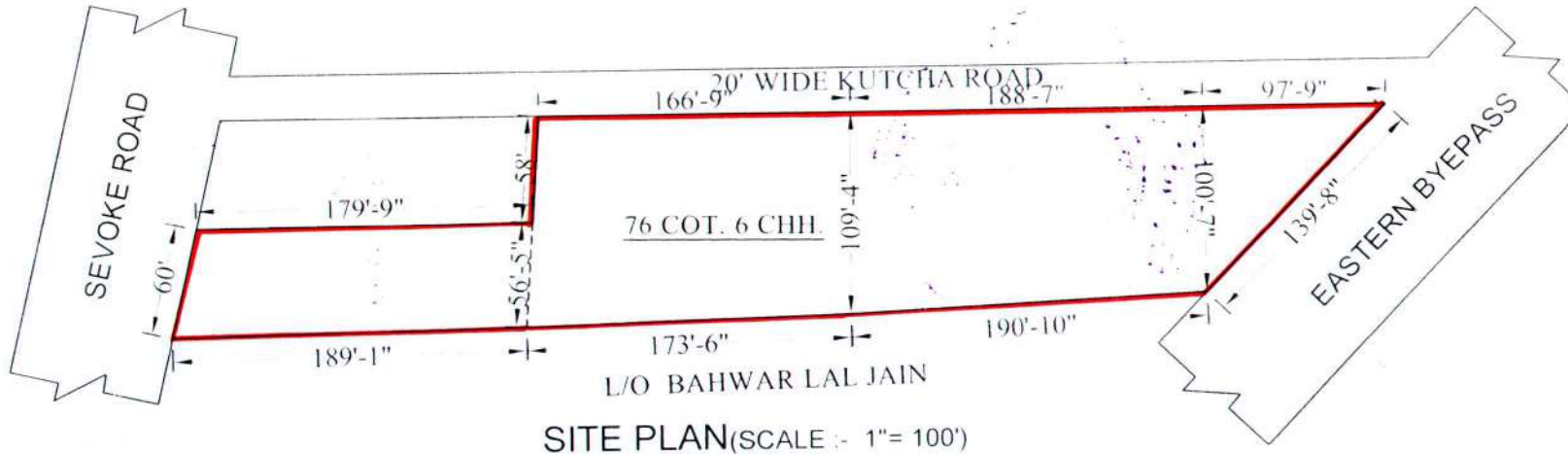

*गोबिन्दा राज*

*Gobinda Roy*

*जमिनी राज*

*FOR SELF & NATURAL  
GUARDIAN OF MINOR*

*JOHNNI ROY SON*

SIGN OF CONFIRMING PARTY

**LAND SCHEDULE**

PARGANA - BAIKUNTHAPUR,  
MOUZA - DABGRAM, JL NO - 2,  
RS SHEET NO. = 5  
RS KH. NO. = 83/1,  
RS PLOT NO. = 133,  
LAND AREA - 76 COT. 6 CHH.

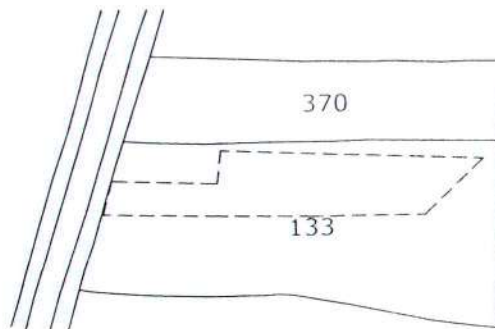

RS MOUZA MAP (SCALE :- 16" = 1 MILE)











ROHINI ENGINEERS PVT. LTD.

*Sang Singh*  
DIRECTOR



  
District Sub-Registrar  
Jalpaiguri









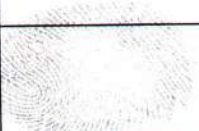

13 SEP 2017

		THUMB	FORE FINGER	MIDDLE FINGER	RING FINGER	LITTLE FINGER
	LEFT HAND					
	RIGHT HAND					

RUMTEK DEVELOPERS PVT. LTD.

*Sanjay Singh*











Signature DIRECTOR

		THUMB	FORE FINGER	MIDDLE FINGER	RING FINGER	LITTLE FINGER
	LEFT HAND					
	RIGHT HAND					

~~TELISA ENTERPH. SA~~

*Sanjay Singh*

Signature

		THUMB	FORE FINGER	MIDDLE FINGER	RING FINGER	LITTLE FINGER
	LEFT HAND					
	RIGHT HAND					

*Pradipt Agarwal*











Signature













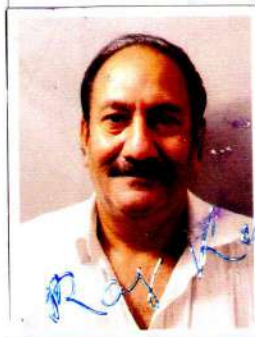

  
District Sub-Registrar  
Jalpaiguri

13 SEP 2017

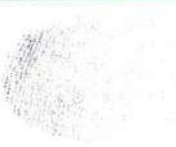
		THUMB	FORE FINGER	MIDDLE FINGER	RING FINGER	LITTLE FINGER
	LEFT HAND					
	RIGHT HAND					

TARA AGARWAL  
 \_\_\_\_\_  
 @ Tara Agarwal  
 Signature











		THUMB	FORE FINGER	MIDDLE FINGER	RING FINGER	LITTLE FINGER
	LEFT HAND					
	RIGHT HAND					

Raj Kumar Aggarwal  
 \_\_\_\_\_  
 Signature



*ehj*  
District Sub-Registrar  
Jalpaiguri

13 SEP 2017

		THUMB	FORE FINGER	MIDDLE FINGER	RING FINGER	LITTLE FINGER
	LEFT HAND					
	RIGHT HAND					

ਅਮਿਤ ਕੌਰ

Signature

 Gobintu Roy		THUMB	FORE FINGER	MIDDLE FINGER	RING FINGER	LITTLE FINGER
	LEFT HAND					
	RIGHT HAND					

Gobintu Roy









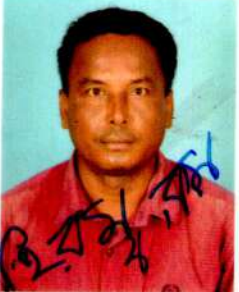

Signature















District Sub-Registrar  
Jalpaiguri

13 SEP 2017

		THUMB	FORE FINGER	MIDDLE FINGER	RING FINGER	LITTLE FINGER
	LEFT HAND					
	RIGHT HAND					

Handwritten signature in blue ink.

Signature

		THUMB	FORE FINGER	MIDDLE FINGER	RING FINGER	LITTLE FINGER
	LEFT HAND					
	RIGHT HAND					

Handwritten signature in black ink.

Signature

स्थायी लेखा संख्या

/PERMANENT ACCOUNT NUMBER

ADBPG1112D



नाम /NAME

SANJAY KUMAR GARG

पिता का नाम /FATHER'S NAME

KHUSIRAM AGARWAL

जन्म तिथि /DATE OF BIRTH

06-07-1975

हस्ताक्षर /SIGNATURE

*Sanjay Garg*

*CBT*

आयकर आयुक्त, प.व. - II

COMMISSIONER OF INCOME-TAX, W.B. - II

RUMTEK DEVELOPERS PVT. LTD.

*Srin*

DIRECTOR