

DAG NO. 3878

PRODUCED BY AN AUTODESK EDUCATIONAL PRODUCT

9527

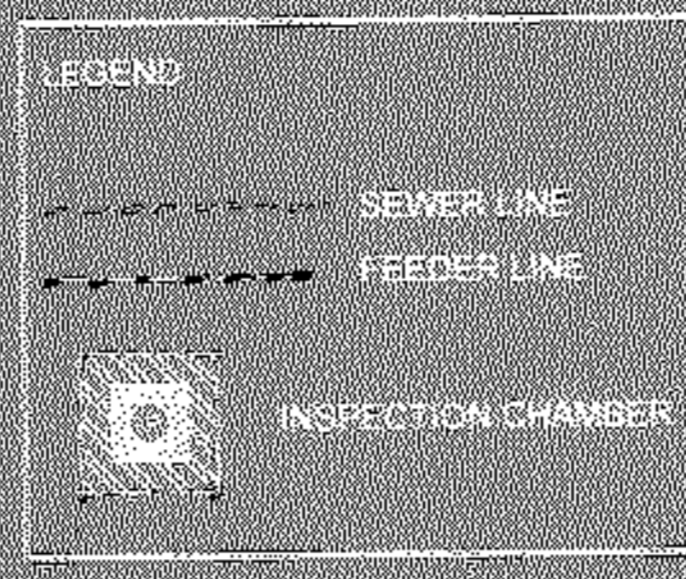

DAG NO. 3885

76220

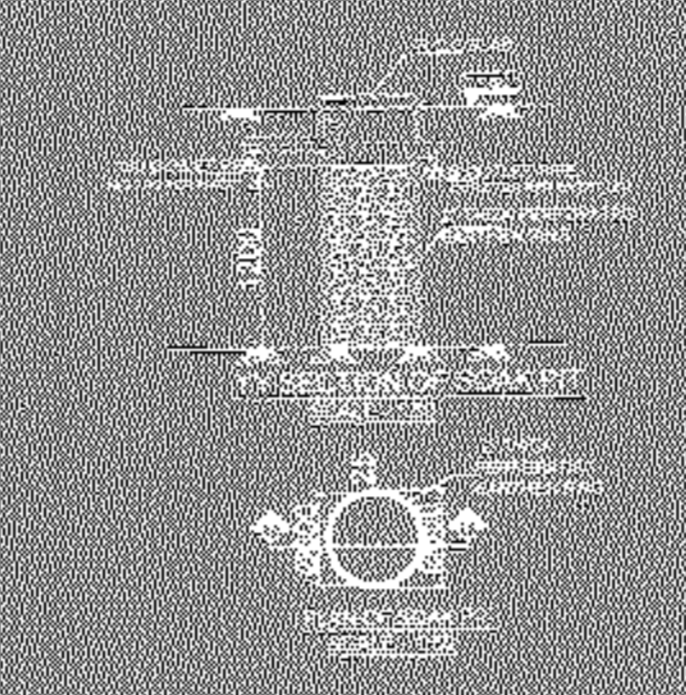

CROSS SECTION OF S.U.W.R.
SCALE-1:50

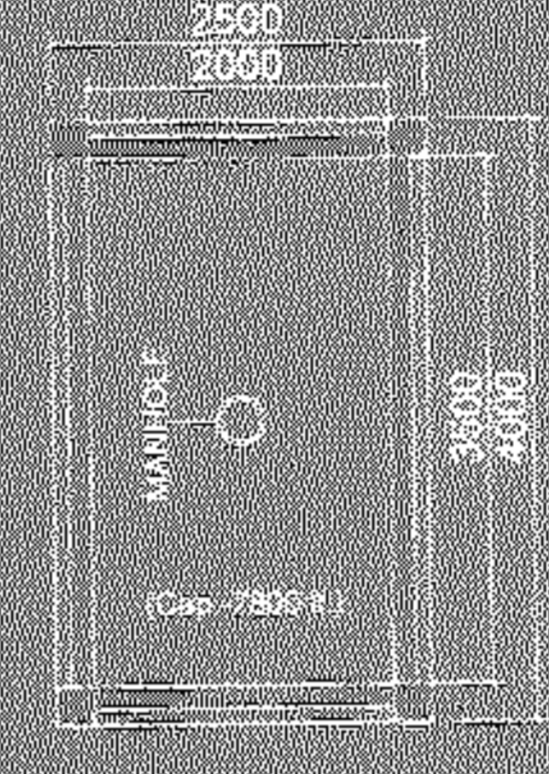

S.U.W.R. PLAN
SCALE-1:50

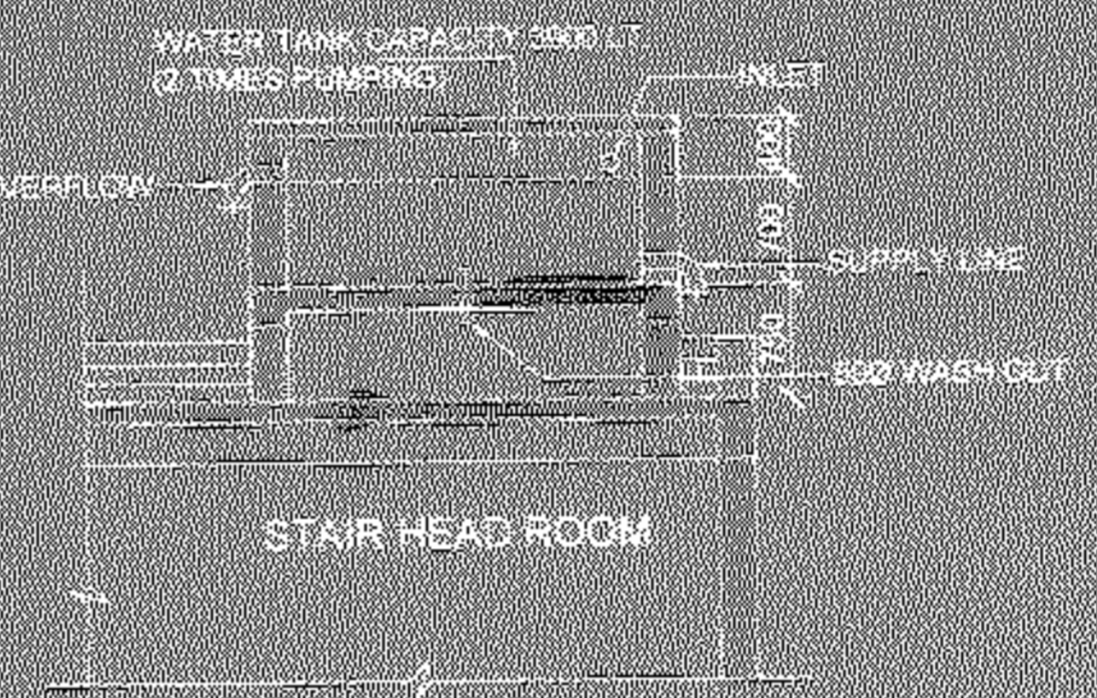

CROSS SECTION OF O.H.W.T.
SCALE-1:50

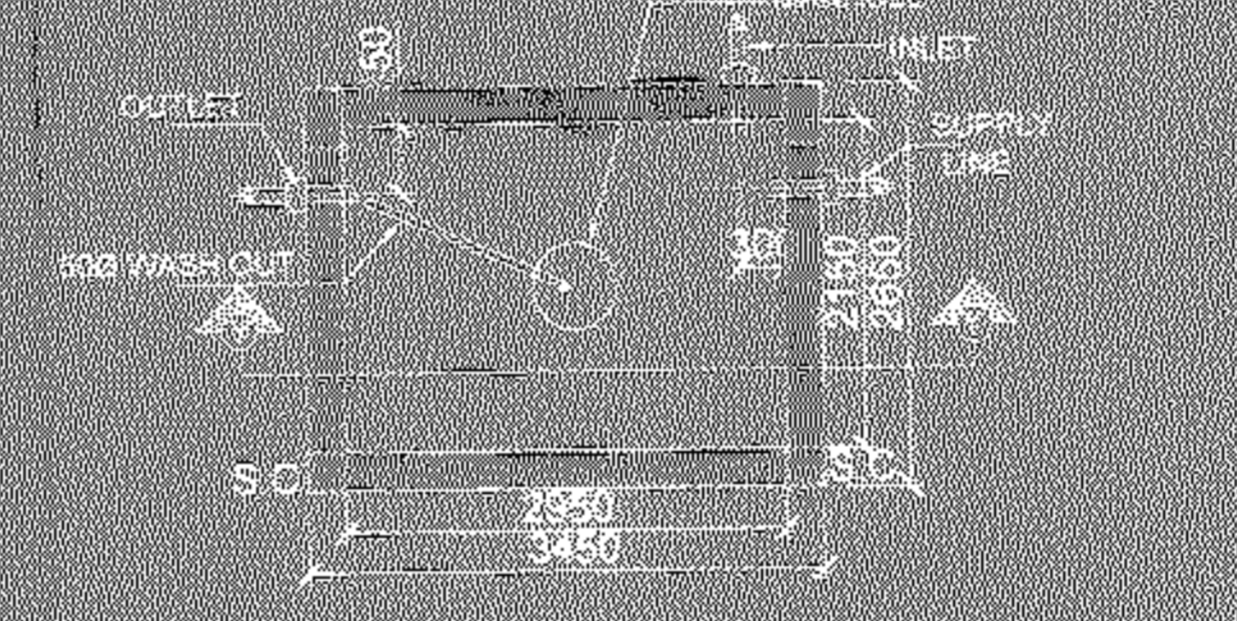

O.H.W.T. PLAN
SCALE-1:50

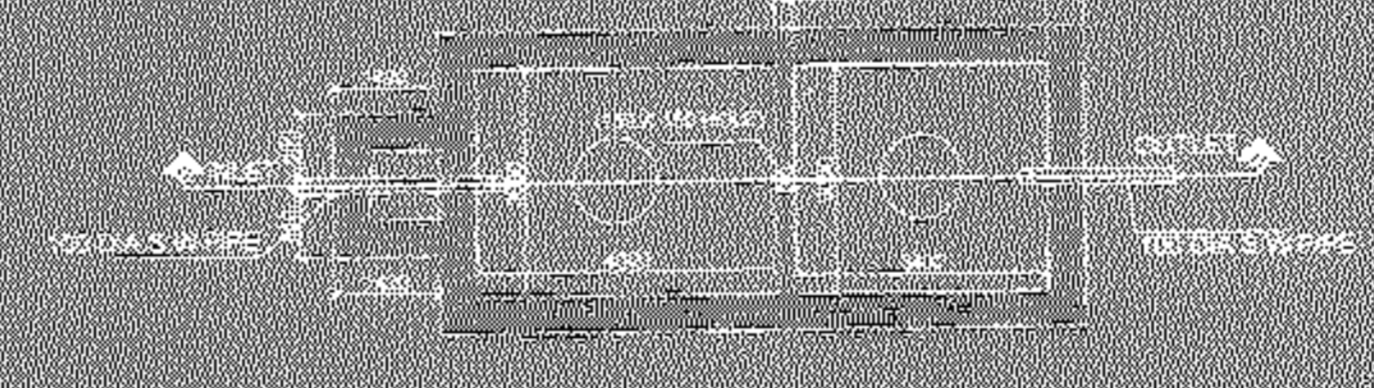

PLAN OF SEPTIC TANK (FOR 100 USERS)
SCALE-1:50



SECTION AT X-X OF SEPTIC TANK
SCALE-1:50

**PROPOSED G+4 STORED
RESIDENTIAL COMPLEX AT
R.S DAG.NO. - 3884 & 3885, MOUZA -
BISHNUPUR, J.L.NO - 44,
R.S KHATIAN NO.- 126,
L.R KHATIAN NO.- 8606,
P.S.- RAJARHAT UNDER CHANDPUR
GRAM PANCHAYET,
DIST.- 24 PARGANAS(N)**

CERTIFICATE ARCHITECT:
CERTIFIED THAT THE PLAN OF G+4 STORED
RESIDENTIAL COMPLEX AT R.S DAG. NO. - 3884 &
3885, MOUZA - BISHNUPUR, J.L. NO - 44, R.S
KHATIAN NO. - 126, L.R KHATIAN NO. - 8606, P.S.
RAJARHAT UNDER CHANDPUR GRAM
PANCHAYET, DIST. - 24 PARGANAS(N) HAS BEEN
DESIGNED AND DRAWN STRICTLY AND
ACCORDINGLY AS STIPULATED IN THE NEW TOWN
KOLKATA PLANNING AREA BUILDING RULES 2014
AND ALSO THE GENERAL BUILDING REQUIREMENTS
OF THE NATIONAL BUILDING CODE OF INDIA AND
OTHER RELEVANT CODES.

AMITAV BISWAS
Chartered Architect
24/2013 / 47702

PRAKALPA™
145, NAM GOPAL ROY CHOWDHURY AVENUE,
Mezzanine & 2nd floor, KOLKATA-700 014
T: 033 64807757 WEB SITE: www.prakalpa.in
E-MAIL: prakalpa.arch@gmail.com

CERTIFICATE ENGINEER:
I HEREBY CERTIFY THAT THE DESIGN AND DRAWING
OF THE SEWERAGE SYSTEM AND SUPER
STRUCTURE OF THE BUILDING HAVE BEEN MADE
BY ME CONSIDERING ALL POSSIBLE LOADS
INCLUDING SEISMIC LOAD AS PER B.C.C. OF INDIA
AND CERTIFIED THAT IT IS SAFE AND STABLE IN ALL
RESPECTS. TESTING REPORT HAS BEEN DONE
BY D. S. K. BANSAL OF SOE ENGINEERS. HAS BEEN
CONSIDERED DURING STRUCTURAL
CALCULATIONS.

SIGNATURE OF THE ENGINEER:

CERTIFICATE OF OWNER:
I DO HEREBY UNDERTAKE WITH FULL
RESPONSIBILITY THAT:
I SHALL ENGAGE (S/A/E/S/E) DURING
CONSTRUCTION.
I SHALL FOLLOW THE INSTRUCTION OF S/A/E/S/E
DURING CONSTRUCTION OF THE BUILDING AS PER
B.S. PLAN.
IF ANY SUBMITTED DOCUMENTS ARE FOUND TO
BE FAKE, THE AUTHORITY WILL REVOKE THE
SANCTION PLAN.
I CERTIFIED THAT I SHALL NOT ON A LATER DATE
MAKE ANY ADDITION OR ALTERATION TO THIS PLAN.
I CERTIFIED THAT I HAVE GONE THROUGH THE
NATIONAL BUILDING CODE OF INDIA AND ALSO
ABIDE BY THOSE RULES DURING AND AFTER
CONSTRUCTION OF THE BUILDING.

SIGNATURE OF THE OWNER: AUTHORIZED SIGNATORY

**TITLE
DRAINAGE AND SEWERAGE PLAN
WITH DETAIL**

PROJECT ARCHITECT	
PRAKALPA™	
145, NAM GOPAL ROY CHOWDHURY AVENUE, MEZZANINE & 2ND FLOOR, KOLKATA-700 014 T: 033 64807757 WEB SITE: www.prakalpa.in E-MAIL: prakalpa.arch@gmail.com	
DRAWN BY:	MELO CHAKRABARTI
CHECKED BY:	ATAMU C
APPROVED BY:	
SCALE:	DATE: 10/01/18
DRIVING NO.:	SUBMISSION DRAWINGS
PROJECT NO.:	REVISION NO.