



2-583/2011

6086 21-2-71



পশ্চিমবঙ্গ পশ্চিমবঙ্গ WEST BENGAL

A 1532

CERTIFIED THAT THE DOCUMENT ADMITTED TO
 REGISTRATION, THE SIGNATURE SHEET AND
 THE ENDORSEMENT SHEETS ATTACHED TO THIS
 DOCUMENT ARE THE PARTS OF THIS DOCUMENT.

ADDL. DIST. SUB-REGISTRAR
 SILIGURI-II, AT BAGDOGRA, DIST.-DARJEELING

22 JUL 2011

Page No. 1

Nabin Roy

DEED OF SALE (CONVEYANCE)

Nabin Roy

DEED OF SALE (CONVEYANCE)

Land measuring	: 17-Decimal
Mouza	: Rupsingh,
J.L. No.	: 95,
Police Station	: Naxalbari,
District	: Darjeeling.
Consideration	: Rs. 15,45,500/-

THIS INDENTURE IS MADE ON THIS THE 22nd DAY OF
JULY, TWO THOUSAND ELEVEN.

BETWEEN

BALASON REALTORS (PRIVATE) LIMITED, a private Limited Company incorporated under the provisions of the Companies Act, 1956, having its registered office at 17, R.N. Mukherjee Road, P.O. R.N. Mukherjee Road, P.S. Hare Street, Kolkata - 700001, in the State of West Bengal - hereinafter called the "**PURCHASER/VENDEE**" (which expression shall mean and include unless excluded by or repugnant to the context its successors and assigns) of the **ONE PART**. The Purchaser is represented through its Executive Officer **MR. BARUN GHOSH**, S/o Late Dharendra Nath Ghosh, who has been appointed to represent the Vendee/Purchaser is these presents by a Resolution dated 05.05.2011 adopted in the meeting of the Board of Directors of the Purchaser/Vendee. PAN - AAECB2020Q.

A N D

Nabin Roy

SRI NABIN ROY, son of Late Kamalu Roy, Hindu by religion, Nationality Indian, Business by Occupation, resident of Rupsing Jote, P.O. & P.S. Bagdogra, District Darjeeling, in the State of West Bengal – hereinafter called the “SELLER/VENDOR” (which expression shall mean and include unless excluded by or repugnant to the context his heirs, successors, legal representatives, executors, administrators and assigns) of the OTHER PART.

WHEREAS the Vendor hereof Sri Nabin Roy is the absolute owner by way of purchase of all that piece or parcel of land measuring 0.68 Acres or 68 decimals, situated within the Mouza – Rupsing, J.L. No. 95, Pargana – Patharghata, P.S. Naxalbari, Dist. Darjeeling, by virtue of a registered Deed of Sale, registered in the office of the Sub-Registrar, Siliguri, District Darjeeling and recorded in Book No. 1, Volume No. 51, Pages from 151 to 154, being document No. 5469 for the year 1987 and thereafter Vendor hereof mutated his name in the office of the B.L. & L.R.O. Naxalbari with respect to his aforesaid land and a separate L.R. Khatian was finally published in his name, being L.R. Khatian No. 667, L.R. Plot No. 203, area 0.68 acre of Mouza Rupsing, J.L.No. 95, P.S. Naxalbari, Dist. Darjeeling and as such from the date of such purchase, the vendor hereof is the absolute and exclusive owner of land measuring 0.68 acre or 68 decimals respectively and got permanent heritable and transferable right, title and interest therein free from all encumbrances and charges whatsoever.

A N D

WHEREAS now the Vendor hereof being in need of money for his own development plans and schemes has decided to sell and have also offered for sale a portion of land measuring 17 decimals out of above land measuring 68 decimals, clearly delineated in the attached sketch map, which is fully described in the schedule appended below, disclosing the aforesaid facts relating thereto and declaring the same free from all encumbrances and charges whatsoever.

A N D

NABITRY

WHEREAS the Purchaser hereof relying on the aforesaid statement of the Vendor, has agreed to purchase the said land measuring 17-Decimal clearly delineated in the attached sketch map fully described in the schedule appended below and offered a price of the sum of Rs. 15,45,500/- (Rupees fifteen lakh forty five thousand five hundred) only, free from all encumbrances and charges whatsoever.

A N D

WHEREAS the Vendor hereof considering the said price so offered by the Purchaser as fair, reasonable and highest in view of prevailing market rate, has firmly and finally agreed to sell his said below scheduled land to the Purchaser hereof at or for the price of the sum of Rs. 15,45,500/- (Rupees fifteen lakh forty five thousand five hundred) only, free from all encumbrances and charges whatsoever and the Vendors already delivered the physical possession of the Schedule mentioned land to the Purchaser/Vendee hereof today and the said land is hereby transferred in the manner as hereinafter appearing.

NOW THIS INDENTURE WITNESSETH that in pursuance of the aforesaid offer, acceptance and also in consideration of the said sum of Rs. Rs. 15,45,500/- (Rupees fifteen lakh forty five thousand five hundred) only, paid by the Purchaser to the Vendor hereof by cash / Bankers cheque today (the receipt whereof the Vendor does hereby acknowledge and grant full discharge from the payment thereof) the Vendors do hereby grant, convey, sell, assign and transfer unto the Purchaser the said land hereby sold described in the schedule below and make over possession thereof to the Purchaser together with all right, title, interest, liberties, easements, privileges, appendices, appurtenances, whichever are belonging to or in any way appertaining to the said land or any part thereof **TO HAVE AND TO**

Nabih Roy

HOLD the same absolutely by the Purchaser forever peaceably and quietly without any interference or interruption from the Vendor or any person or persons claiming under him/her, subject to the payment of rent etc. payable to the Superior Landlord The Govt. of West Bengal.

THE VENDOR does hereby declare that the VENDOR does has not previously sold, mortgaged, transferred or contracted for sale or otherwise the said vacant land hereby sold or any part thereof suffers from no defect of title and in the event of discovery or any contrary is proved, the Vendor shall be liable to be dealt with according to law both Civil and Criminal as the case may be and shall be also liable to return back the consideration money along with 18% interest per annum to the Purchaser hereof.

THE VENDOR does hereby covenant with the Purchaser that if for any defect in the title of the land hereby sold or any part thereof or for any act done or suffered to be done by the Vendors, the Purchaser is deprived of ownership or of possession thereof the land hereby sold or any part thereof in future, the Vendor shall be liable to return back the consideration money along with 18% interest per annum to the Purchaser hereof from the date of purchase and the Vendor shall also be liable to pay adequate compensation to the Purchaser for any other loss or injury which the Purchaser may suffer there from.

THE VENDOR does hereby further declare that the Vendor at the request and costs of the Purchaser, do execute or cause to be done such acts, deeds or things whatsoever if the Purchaser so required in future for peaceful enjoyment and possession of the said land hereby sold by the Vendor by these presents.

SCHEDULE

Nabir Roy

ALL THAT PIECE OR PARCEL of vacant land measuring 17-decimal, recorded in

L.R. Khatian No.	R.S. Plot No.	L.R. Plot No.	Area
667	125	203	17 Decimals

of land is hereby sold by the Vendor to the Purchaser hereof by these presents, situated within Pargana Patharghata, Mouza - RUPSING, J.L. No. 95, Police Station Naxalbari, District Darjeeling, in the State of West Bengal. Gram Panchayat area, Classification of land Rupni, and the said demised land is butted and bounded as follows:-

- By the North : Land of Hill Cart Realtors Pvt. Ltd.;
- By the South : Land of Hill Cart Realtors Pvt. Ltd.;
- By the East : Land of Vendor;
- By the West : Land of Vendor;

Within the aforesaid boundary 17-decimal of land is hereby sold by the Vendor to the Purchaser hereof by these presents and a map or plan annexed herewith forming part of these presents.

Nabin Roy

IN WITNESS WHEREOF the Vendors hereof in good health and conscious mind have put their signature on this Deed of Sale on the day, month and year hereinbefore mentioned.

WITNESSES :

1. *Nabin Roy*

S/o Late Deben Roy,
Of Rupsingh Jote, Gossainpur,
P.S. Naxalbari,
Dist. Darjeeling.
Occupation : Business.

2.

S/o Sri Marawari Oraon,
Of Rupsingh Jote, Gossainpur,
P.S. Bagdogra,
Dist. Darjeeling.

Drafted, read over and
explained by me and
computerized in my chamber:

Himadri Mohanta
Advocate / Siliguri.

Enrolment No. WB-1034/2002.

PART TRACE MAPE OF MOUZA RUPSINGH, J.L. NO. 95, P.S.- NAXALBARI , TOUJI NO. 91, PARGANA- PATHARGHATA, DISTRICT- DARJEELING.

SCALE : 1/8" = 1 MILE

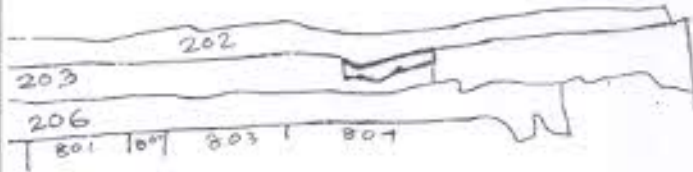

SCALE 1 INCHES = 40 FEET

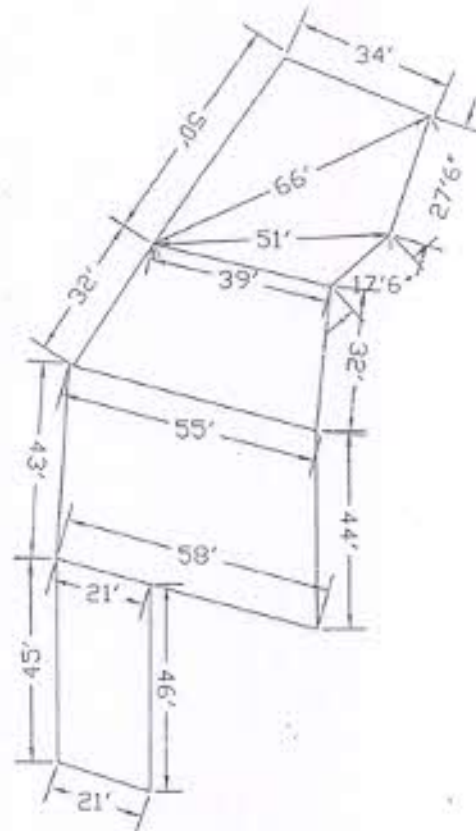

NAME OF VENDOR

SRI NABIN ROY SON OF LATE KAMALU ROY OF RUPSINGJOTE, P.O AND P.S. BAGDOGRA, DIST. DARJEELING.

SITE PLAN OF PROPOSED LAND AS PER POSSESSION

PLOT NO.

KHATIAN NO.

R.S.- 125, L.R. -203

667

AREA

17.0 DECIMAL OR 0.17 ACRE

LAND BOUND AND BUTTED

BY NORTH : LAND OF HILL CART REALTORS PVT. LTD.,
 BY SOUTH : LAND OF HILL CART REALTORS PVT. LTD.,
 EAST : LAND OF HILL CART REALTORS PVT. LTD., BY
 WEST : LAND OF VENDOR.

NAME OF PURCHASER

BALASON REALTORS PRIVATE LIMITED,
 OF 17, R.N. MUKHERJEE ROAD, P.O. R.N.
 MUKHERJEE ROAD, P.S. HARE STREET,
 KOLKATA-1.

DRAWN BY :

Krishna Oraan

20/1/2014, BAGDOGRA,
 DARJEELING, PIN-734014
 REGD. NO. 15/270/006

Nabin Roy

SIGNATURE OF SELLER

Finger Prints of _____



	Thumb	Fore Finger	Middle Finger	Ring Finger	Little Finger
Left Hand					
Right Hand					

Nabir Roy
Signature

Finger Prints of _____



	Thumb	Fore Finger	Middle Finger	Ring Finger	Little Finger
Left Hand					
Right Hand					

Signature

Finger Prints of _____



	Thumb	Fore Finger	Middle Finger	Ring Finger	Little Finger
Left Hand					
Right Hand					

Nabir Roy
Signature

Government of West Bengal
Department of Finance (Revenue), Directorate of Registration and Stamp Revenue
Office of the ADSR Siliguri-II at Bagdogra, District- Darjeeling
Signature / LTI Sheet of Serial No. 05831 / 2011, Deed No. (Book - I , 06086/2011)

I . Signature of the Presentant

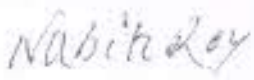
Name of the Presentant	Signature with date
Nabin Roy	

II . Signature of the person(s) admitting the Execution at Office.

Sl No.	Admission of Execution By	Status	Photo	Finger Print	Signature
1	Nabin Roy Address -Rupsing Jote, Thana:-Bagdogra, District:-Darjeeling, WEST BENGAL, India, P.O. :-Bagdogra	Self	 22/07/2011	 LTI 22/07/2011	

Name of Identifier of above Person(s)

Nirmal Roy
Rupsing Jote, Thana:-Bagdogra, District:-Darjeeling,
WEST BENGAL, India, P.O. :-Bagdogra

Signature of Identifier with Date

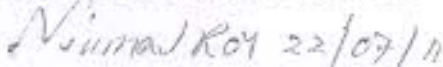
Nirmal Roy 22/07/11

(Dhruva Dasgupta)
A.D.S.R. Siliguri-II at Bagdogra
Office of the ADSR Siliguri-II at Bagdogra



Government Of West Bengal
Office Of the ADSR Siliguri-II at Bagdogra
District:-Darjeeling

Endorsement For Deed Number : I - 06086 of 2011
(Serial No. 05831 of 2011)

On

Payment of Fees:

On 22/07/2011

Certificate of Admissibility(Rule 43,W.B. Registration Rules 1962)

Admissible under rule 21 of West Bengal Registration Rule, 1962 duly stamped under schedule 1A, Article number : 23 of Indian Stamp Act 1899. also under section 5 of West Bengal Land Reforms Act, 1955; Court fee stamp paid Rs.10/-

Payment of Fees:

Amount By Cash

Rs. 16995/-, on 22/07/2011

(Under Article : A(1) = 16995/- on 22/07/2011)

Certificate of Market Value(WB PUVI rules of 2001)

Certified that the market value of this property which is the subject matter of the deed has been assessed at Rs.-1545500/-

Certified that the required stamp duty of this document is Rs.- 77275 /- and the Stamp duty paid as: Impresive Rs.- 5000/-

Deficit stamp duty

Deficit stamp duty

1. Rs. 70000/- is paid, by the draft number 278575, Draft Date 21/07/2011, Bank Name State Bank of India, NORTH BENGAL UNIV CMPUS, received on 22/07/2011
2. Rs. 5000/- is paid, by the draft number 278578, Draft Date 21/07/2011, Bank Name State Bank of India, NORTH BENGAL UNIV CMPUS, received on 22/07/2011

Presentation(Under Section 52 & Rule 22A(3) 46(1),W.B. Registration Rules,1962)

Presented for registration at 12.29 hrs on :22/07/2011, at the Office of the ADSR Siliguri-II at Bagdogra by Nabin Roy ,Executant.

Admission of Execution(Under Section 58,W.B.Registration Rules,1962)

Execution is admitted on 22/07/2011 by

1. Nabin Roy, son of Late Kamalu Roy , Rupsing Jote, Thana:-Bagdogra, District: Darjeeling/ WEST BENGAL, India, P.O. :-Bagdogra , By Caste Hindu, By Profession : Business



(Dhruva Dasgupta)

A.D.S.R. Siliguri-II at Bagdogra
EndorsementPage 1 of 2

22/07/2011 13:31:00



Government Of West Bengal
Office Of the ADSR Siliguri-II at Bagdogra
District:-Darjeeling

Endorsement For Deed Number : I - 06086 of 2011
(Serial No. 05831 of 2011)

Identified By Nirmal Roy, son of Late Deben Roy, Rupsing Jote, Thana:-Bagdogra,
District:-Darjeeling, WEST BENGAL, India, P.O. :-Bagdogra , By Caste: Hindu, By Profession:
Business.

(Dhruba Dasgupta)
A.D.S.R. Siliguri-II at Bagdogra

(Dhruba Dasgupta)
A.D.S.R. Siliguri-II at Bagdogra

Certificate of Registration under section 60 and Rule 69.

Registered in Book - I
CD Volume number 15
Page from 5601 to 5614
being No 06086 for the year 2011.



(Dhruba Dasgupta) 28-July-2011
A.D.S.R. Siliguri-II at Bagdogra
Office of the ADSR Siliguri-II at Bagdogra
West Bengal