



SPECIFICATIONS :-

1. SOILING WITH FIRST CLASS BRICK.
2. 1:3 CEMENT CONCRETE.
3. 1:3:6 CEMENT CONCRETE.
4. D.P.C.
5. GRADE OF CONCRETE: M25 GRADE OF CONCRETE.
6. FLOORING: POLISHED MARBLE FLOORING.
7. F-500 GRADE.
8. BRICK WALL: 230 THICK AND 125 THICK WITH 4:1 SAND CEMENT MORTAR.
9. PLASTERING: 20MM & 15 MM THICK WITH 4:1 SAND CEMENT MORTAR.
10. DOORS: 37.5 MM PANEL SHUTTER WITH 125 X 62.5 MM SAL FRAME.
11. WINDOWS: ALUMINIUM WINDOW FRAMES WITH GLASS.
12. PAINTING: ALUMINIUM WINDOW FRAMES WITH SYNTHETIC ENAMEL PAINTING IN DOORS.
13. DECORATIVE CEMENT BASED PAINTS ON EXTERIOR WALLS.
14. ALL ELECTRICAL AND MECHANICAL WORK AS PER SPECIFICATIONS.
15. ARTIFICIAL LIGHTING AND MECHANICAL VENTILATION PROVIDED.

PROJECT:

PLAN SHOWING THE LAND FOR PROPOSED GROUND (PARKING) + FIVE STORED RESIDENTIAL BUILDING TO BE CONSTRUCTED BY 1. SRI. MAOJ KUMAR AGARWAL 2. SRI. NARESH KUMAR AGARWAL BOTH ARE S/O LATE MOTILAL AGARWAL AT UPPER BHANUNAGAR, SILIGURI, WARD NO-43(S.M.C) P.S.- BHAKTINAGAR, DIST.- JALPAIGURI.

SCHEDULE OF DOORS & WINDOWS

TYPE	SIZE	TYPE	SIZE
C/G-1	2340 X 2100	W1	1800 X 1500
D	1200 X 2100	W2	1500 X 1500
D1	900 X 2100		
D2	750 X 2100	V	600 X 600
		SW1	1200 X 1500
		SW2	1500 X 1800

CERTIFICATE OF STRUCTURAL STABILITY

I do hereby certify that the foundation and superstructure of the building proposed for construction on plot R.S. 254(P) & 255(P) L.R. 261, Street Upper BHANUNAGAR, Ward No. 43, under the jurisdiction of SILIGURI, Municipality / Notified Area Authority / Industrial Township Authority have been personally inspected and designed by me (I) with my seal and signature and support structure safe in all respect including stipulations of all relevant IS Code of practice and National Building code.

Signature of Structural Engineer
 (Name, Address and Empancement No.)

Signature of Geotechnical Engineer
 (Name, Address and Empancement No.)

CERTIFICATE OF BUILDING PLAN

I do hereby certify that plans, elevations and sections and other structural details of the proposed building on Plot No. R.S. 254(P) & 255(P) L.R. 261, Ward No. 43 under the jurisdiction of S.M.C. Municipality / Notified Area Authority / Industrial Township Authority have been prepared in conformity with all relevant provisions from the respective Authorities such as Fire and Emergency Services, Sanitation, Public Health, Gas, Water, Board, Telecommunication Department etc. as applicable in this regard, are enclosed with the application for seeking approval of the plan to construct/reconstruct/addition to/alteration of the building on the said plot.

Signature of Licensed Building Surveyor/Architect
 (Name, Address and Empancement No. / Registration No.)

DECLARATION OF OWNER:-

I do hereby declare that the building proposed for construction shall be supervised by the L.B.A./L.B.S. signing the Building Plan Application or in his/her absence by any other L.B.A./L.B.S. of the appropriate category and as approved by the authority.

SIGNATURE OF OWNER(S)

Naresh Kumar Agarwal
Maaj Kumar Agarwal

Valid for Three Years
 Passed in the Board Meeting
 Held on 25-2-19
 Sanctioned as per Approved
 Master Copy.

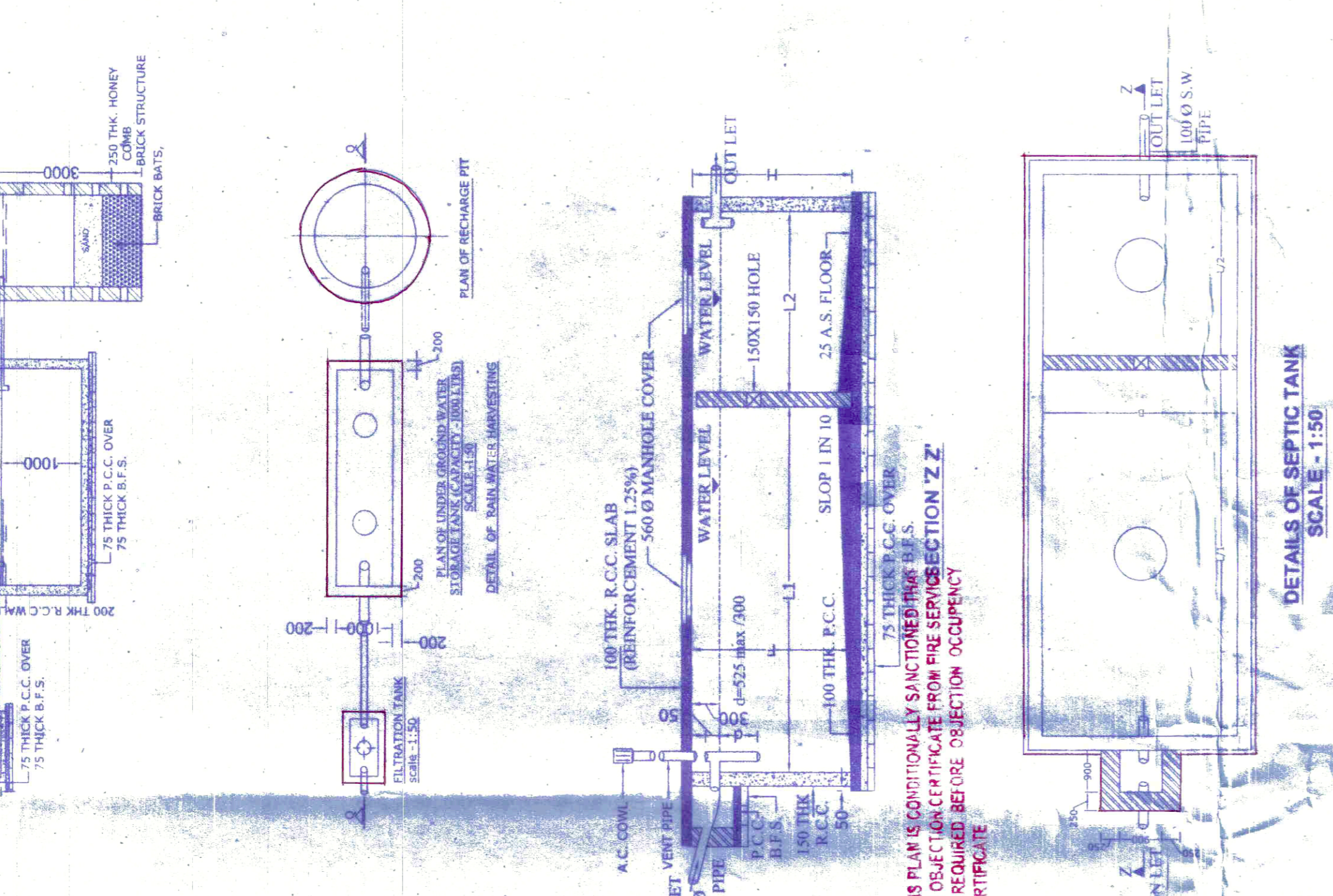

DETAILS OF SEPTIC TANK
 SCALE - 1:50

NO OF USERS	DIMENSION OF TANK				DIMENSION OF S.WELL			
	L	B	F	H	L	B	F	D
200-500	2000	1000	2700	1400	1700	3000	1000	1950
500-1000	3000	1500	3300	1400	1700	3000	1000	1950
1000-1500	3500	1500	3300	1400	1700	3000	1000	1950
1500-2000	4000	1500	3300	1400	1700	3000	1000	1950
2000-2500	4500	1500	3300	1400	1700	3000	1000	1950
2500-3000	5000	1500	3300	1400	1700	3000	1000	1950
3000-3500	5500	1500	3300	1400	1700	3000	1000	1950
3500-4000	6000	1500	3300	1400	1700	3000	1000	1950
4000-4500	6500	1500	3300	1400	1700	3000	1000	1950
4500-5000	7000	1500	3300	1400	1700	3000	1000	1950

TENAMENT AREA

- A-115.38 SQ.M. (each x 5)
- B-107.45 SQ.M. (each x 5)
- C-114.71 SQ.M. (each x 5)
- D-115.38 SQ.M. (each x 5)
- E-137.50 SQ.M. (each x 5)
- F-125.81 SQ.M. (each x 5)
- G-125.81 SQ.M. (each x 5)
- H-137.05 SQ.M. (each x 5)

STAIR CASE AREA - 127.76 sq.mt

Placed in the Building Committee Meeting
 Held on 25-2-19 & Recommended

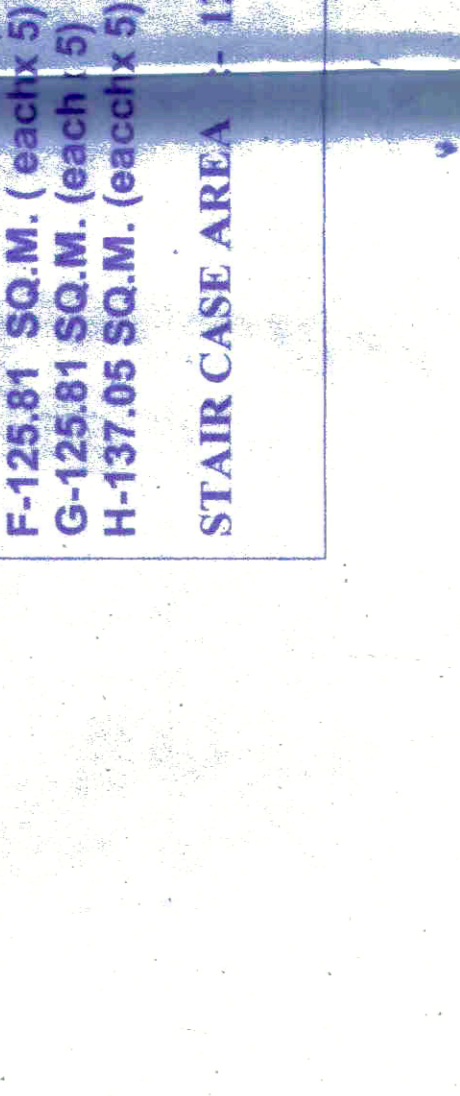
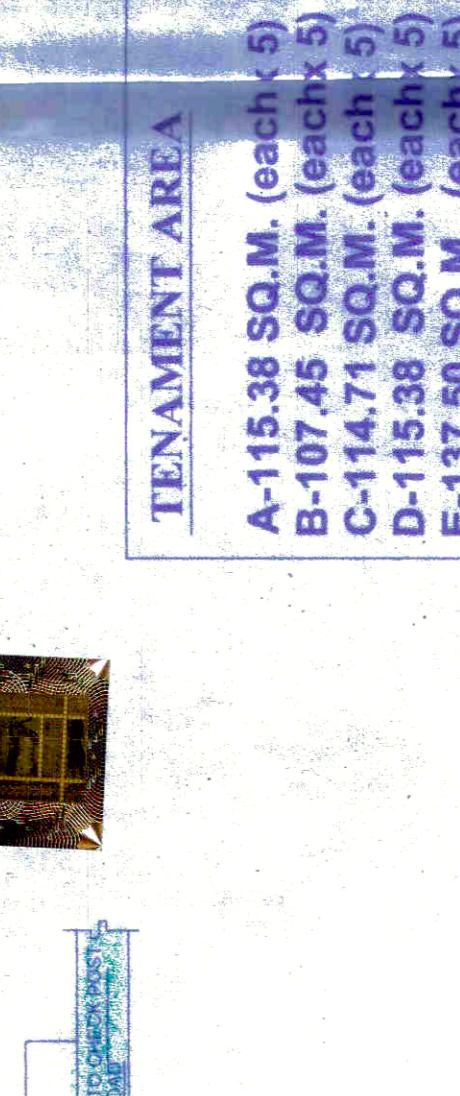
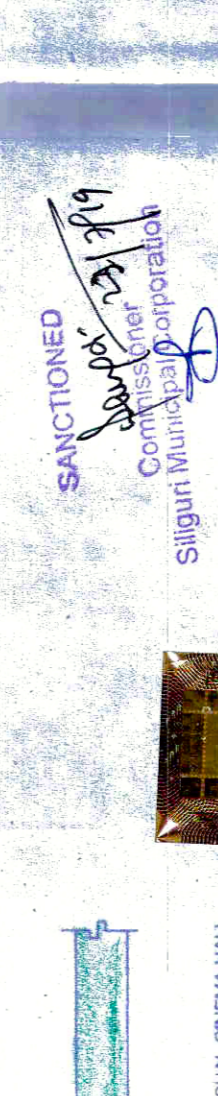
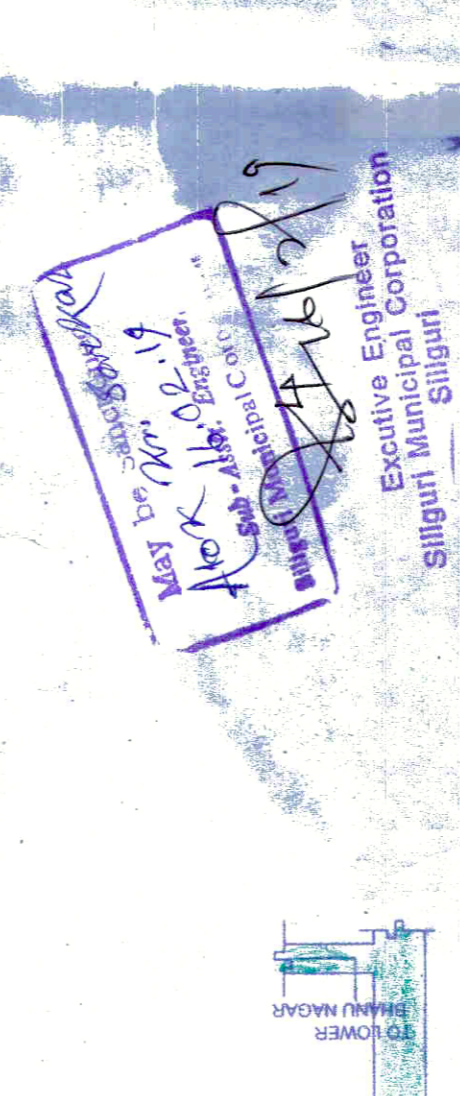
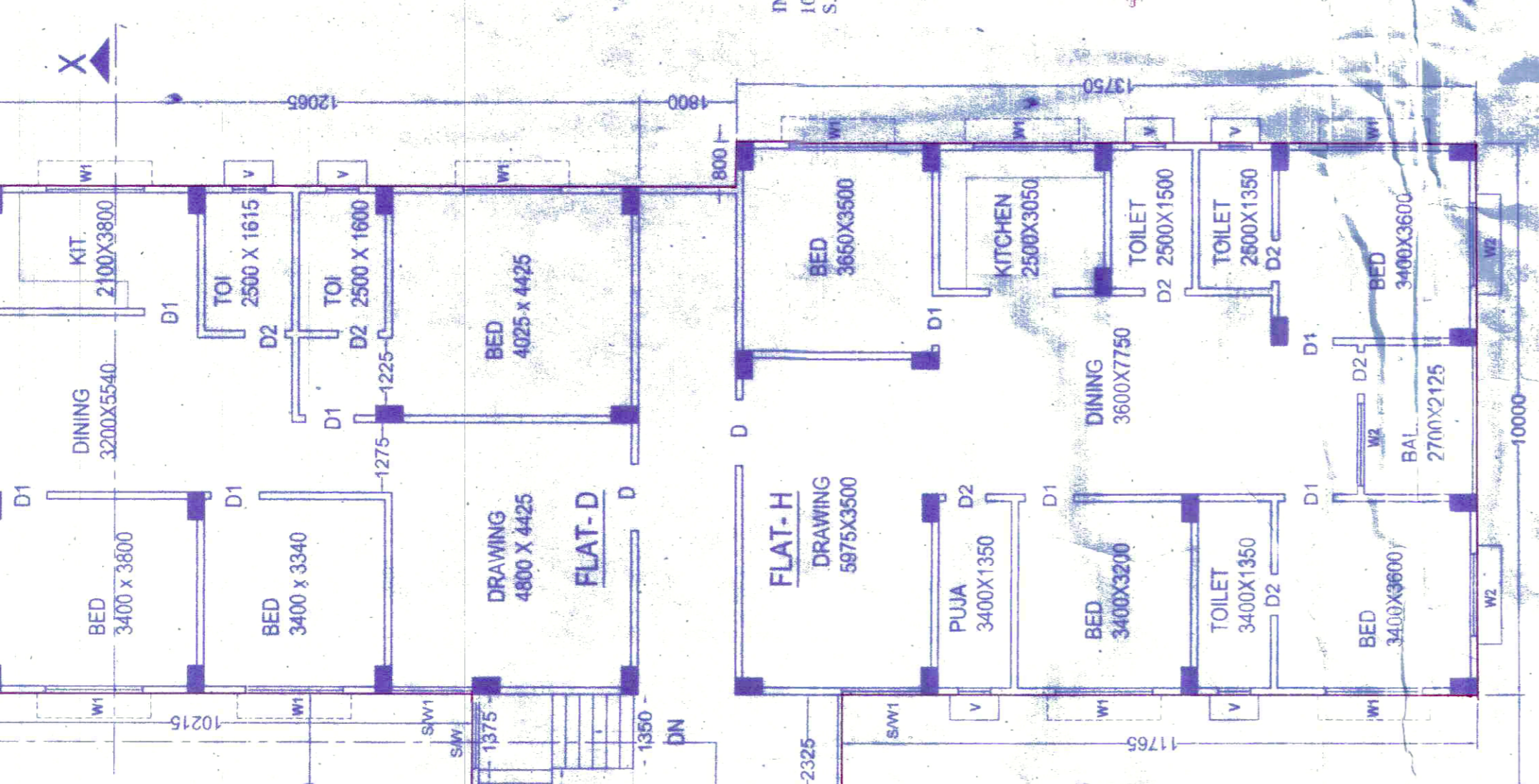

TYPICAL (1ST, 2ND, 3RD, 4TH & 5TH) FLOOR PLAN Y
 SCALE - 1:100

SECTIONAL ELEVATION
 BRICK WALL FOUNDATION
 SCALE = 1:25

DETAIL IN THE STRUCTURAL DESIGN AND DRAWING SHEET
 1:25 & 250 THICK

Placed in the Board Meeting
 Held on 25-2-19

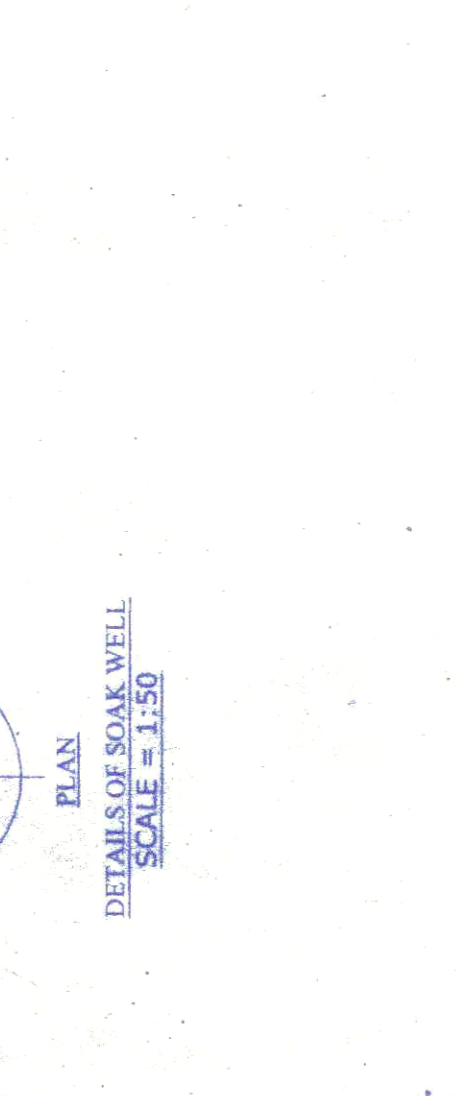
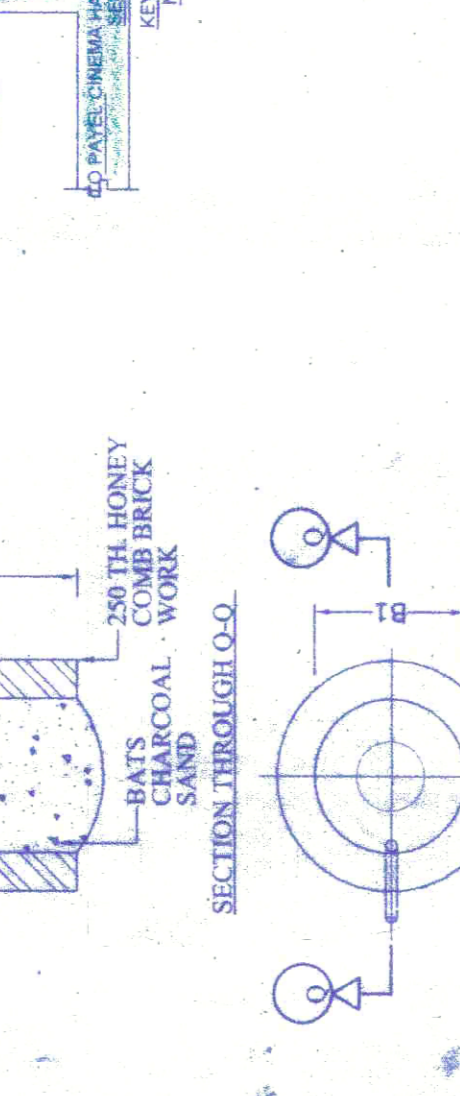
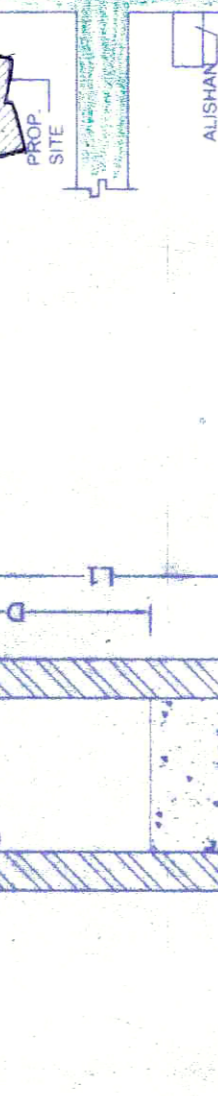
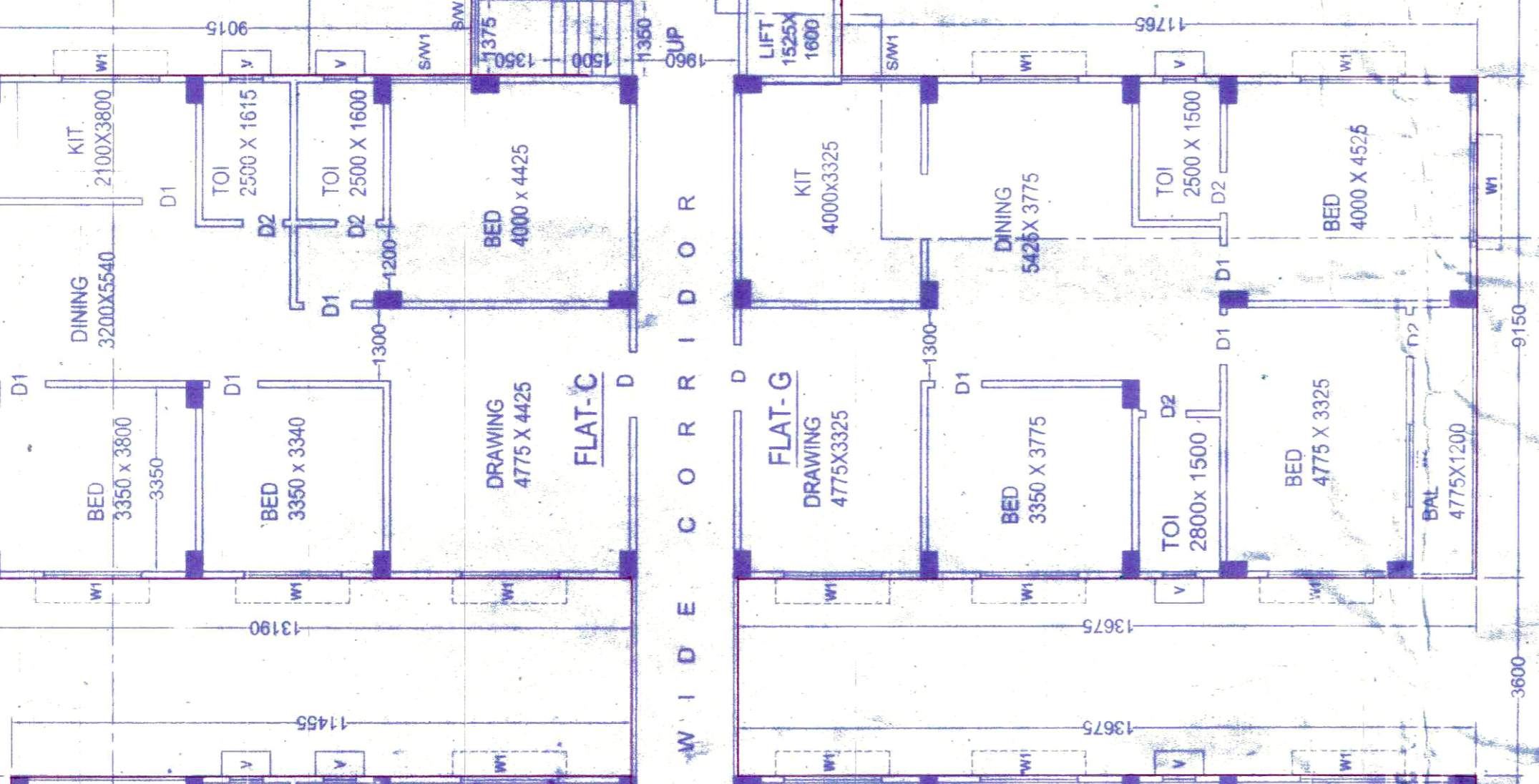

TYPICAL (1ST, 2ND, 3RD, 4TH & 5TH) FLOOR PLAN Y
 SCALE - 1:100

SECTIONAL ELEVATION
 BRICK WALL FOUNDATION
 SCALE = 1:25

DETAIL IN THE STRUCTURAL DESIGN AND DRAWING SHEET
 1:25 & 250 THICK

Placed in the Board Meeting
 Held on 25-2-19

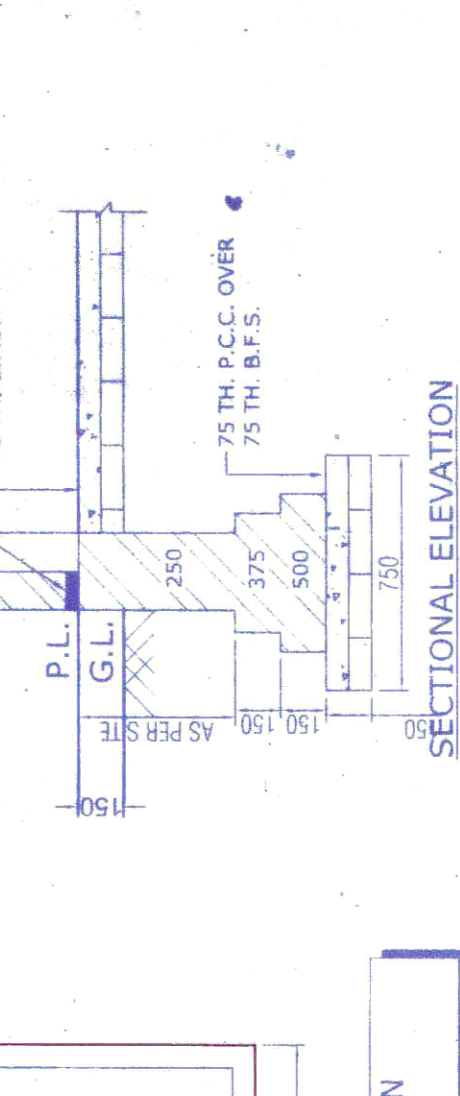
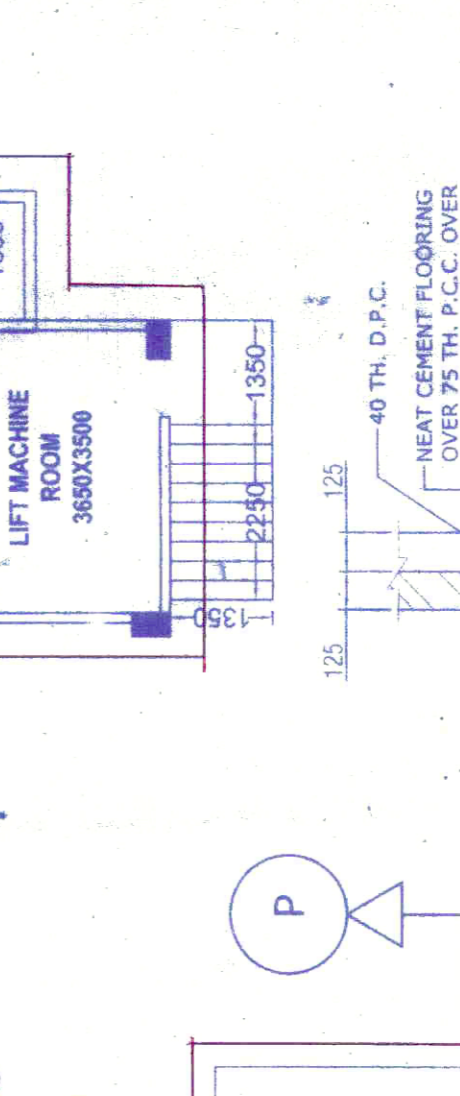
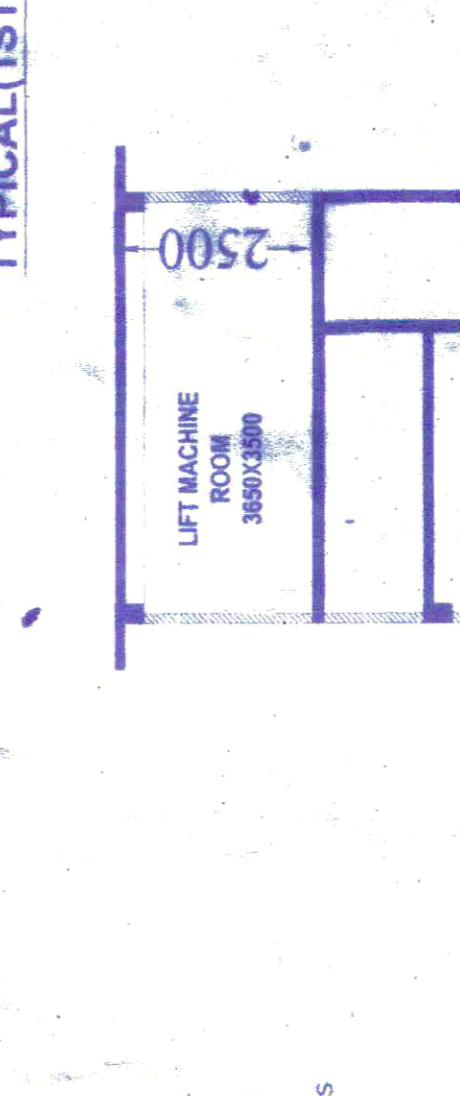
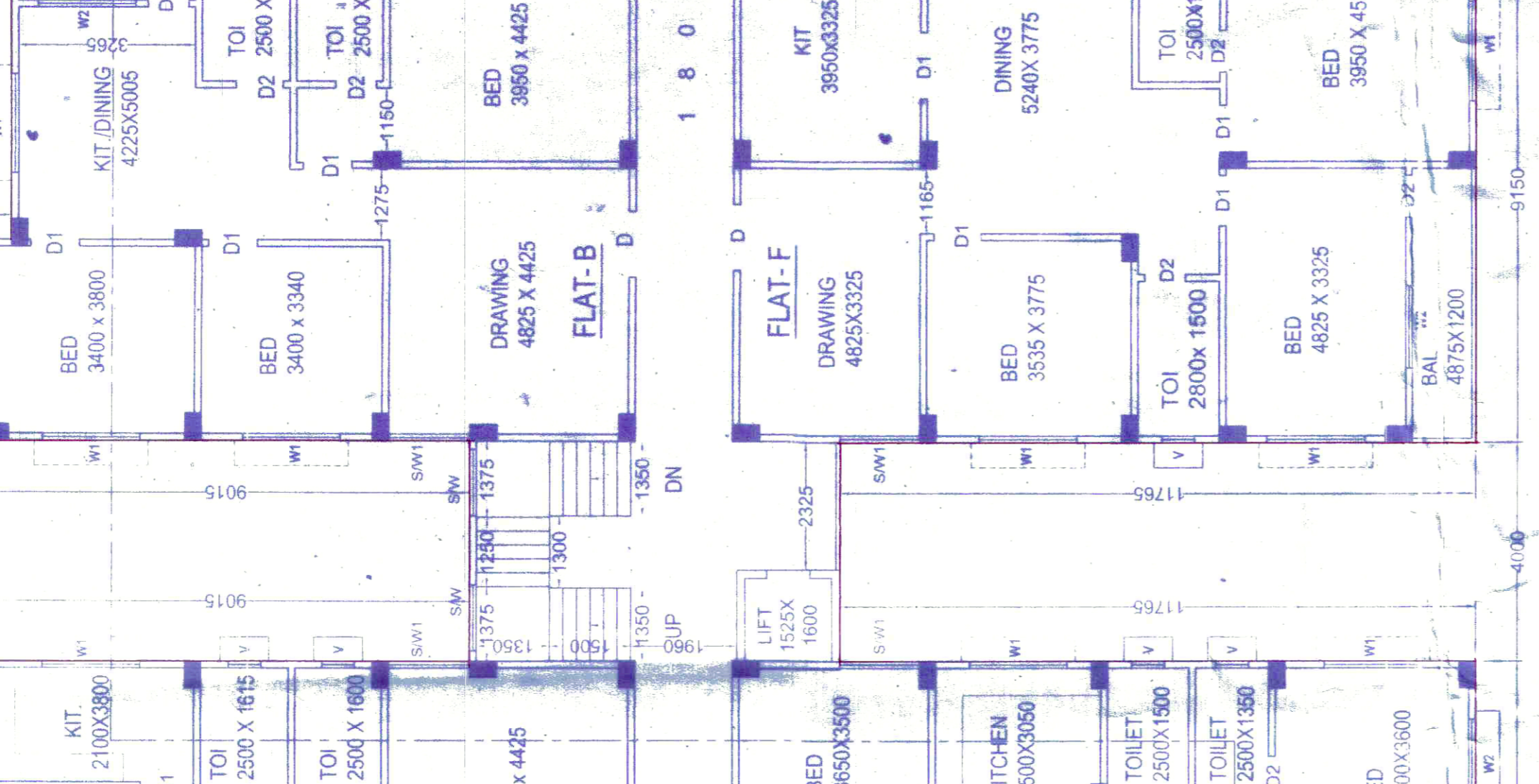

TYPICAL (1ST, 2ND, 3RD, 4TH & 5TH) FLOOR PLAN Y
 SCALE - 1:100

SECTIONAL ELEVATION
 BRICK WALL FOUNDATION
 SCALE = 1:25

DETAIL IN THE STRUCTURAL DESIGN AND DRAWING SHEET
 1:25 & 250 THICK

Placed in the Board Meeting
 Held on 25-2-19

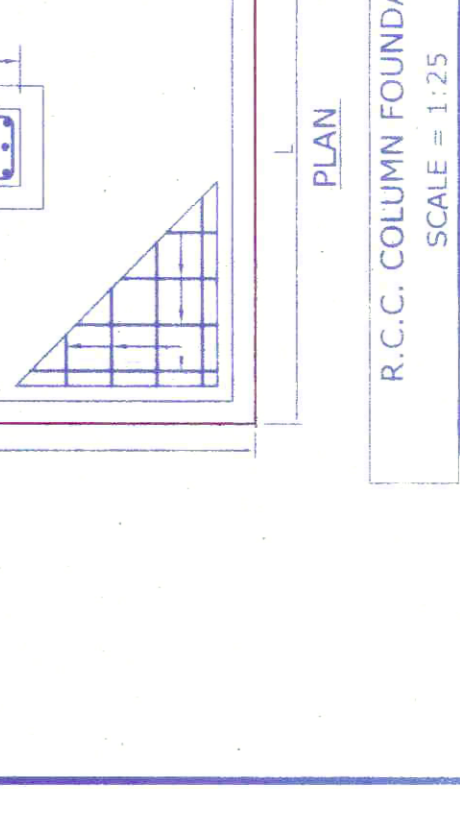
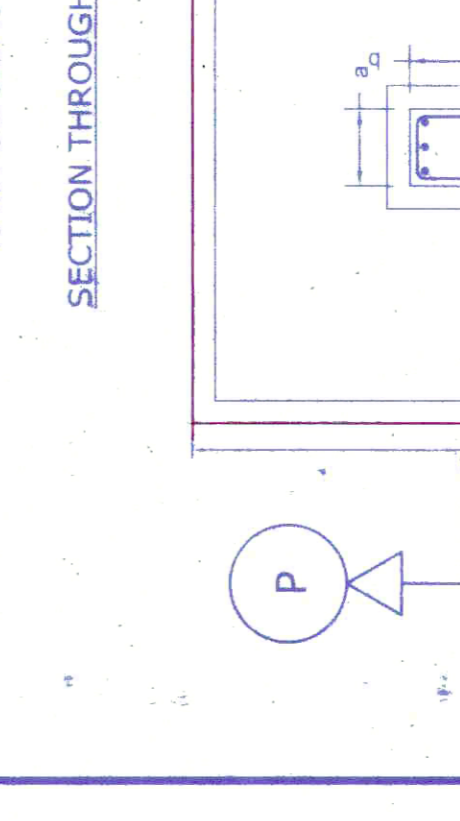
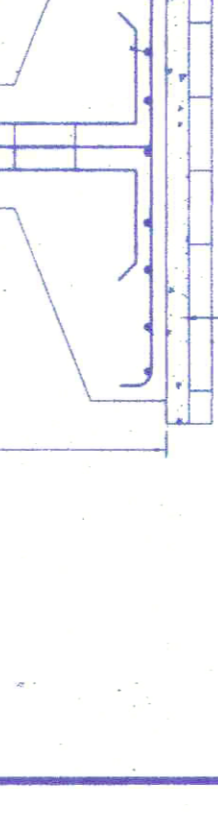
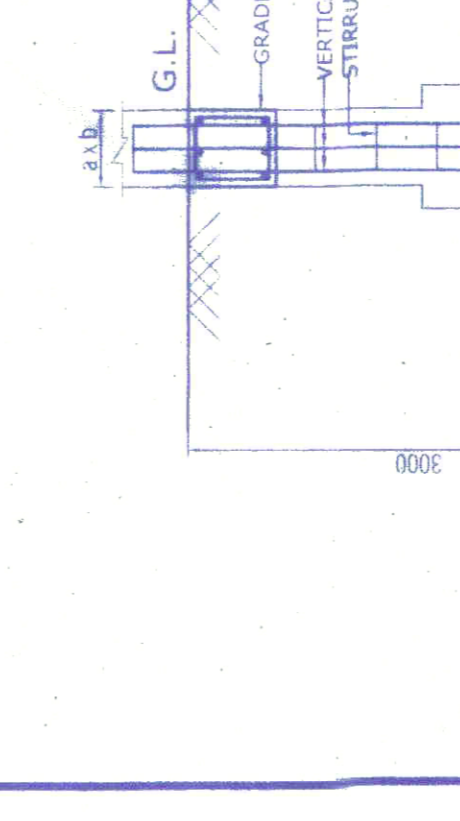
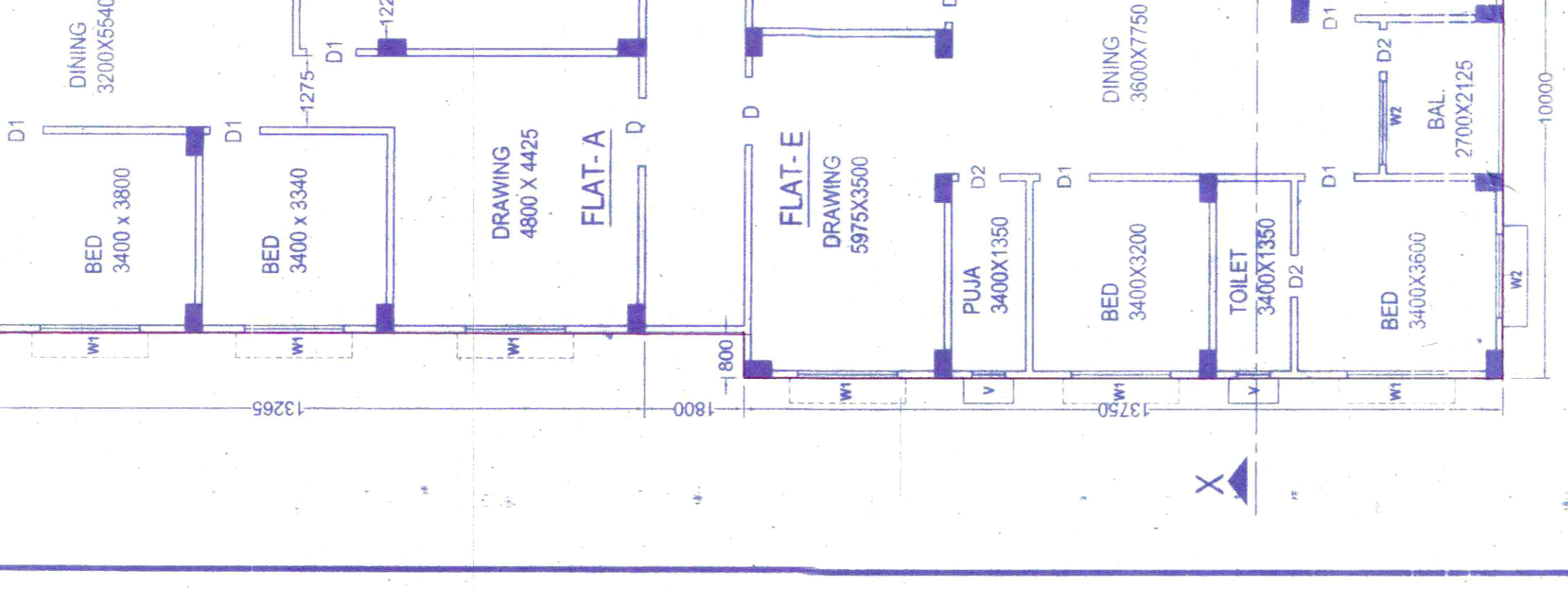

TYPICAL (1ST, 2ND, 3RD, 4TH & 5TH) FLOOR PLAN Y
 SCALE - 1:100

SECTIONAL ELEVATION
 BRICK WALL FOUNDATION
 SCALE = 1:25

DETAIL IN THE STRUCTURAL DESIGN AND DRAWING SHEET
 1:25 & 250 THICK